



AMSAT-OSCAR-7 A Still Operational, Small-Satellite History Lesson

Jan A. King

W3GEY

AMSAT AO-7 Project Manager
Radio Amateur Satellite Corporation (AMSAT);
126 The Avenue, Peregian Springs
QLD, Australia 4572
Cell: +61-(0)423-952-425
jan@astrodigital.com

Frank Wiesenmeyer

K9CIS,

Professor Emeritus, Electronics, Richland
Community College, Decatur, IL;
fwmeyer@richland.edu

Scott Wiesenmeyer

K7WDO

Network Administrator,
Pacific University, Portland OR
swezen@pacificu.edu

August 3, 2024

Table of Contents

	Abstract	3
1.0	Introduction	4
1.1	Lucky AO-7.....	4
1.2	This Has Been Going on for a Long Time	6
2.0	AO-7 Mission Concept and AMSAT OSCAR-6.....	7
2.1	Experimenter’s Meetings.....	7
3.0	The Detailed Design and Fabrication of a Complex Small Satellite	8
3.1	Comparative Models and Methods.....	8
3.2	Amateur Radio Experiments and their Implementation	9
3.2.1	The VHF/HF Transponder (Mode A).....	9
3.2.2	The UHF/VHF Transponder (Mode B)	10
3.2.3	The 435 MHz Beacon Transmitter	12
3.2.4	The 2304 MHz Beacon Transmitter	12
3.2.5	The Morse Code Telemetry System	13
3.2.6	The RTTY Telemetry System	14
3.2.7	CodeStore	15
3.2.8	The Command System	16
3.2.9	The Experiment Control Logic (ECL).....	17
3.2.10	The VHF/UHF Antenna Combiner	18
3.3	Amateur Space Experiments and Their Implementation	20
3.3.1	The Battery Charge Regulator (BCR)	20
3.3.2	The Photon Propeller; A Passive Player in Our System	21
3.3.3	Radiation; Total Dose; CMOS and Other Devices	23
3.3.4	Piece Parts Reliability Experiments	25
3.4	Lifetime Expectations.....	26
4.0	Testing and Preparing For Launch	26
4.1	Environmental Test Program.....	27
4.2	Functional Testing of AO-7.....	28
4.3	Let’s Launch It	29
5.0	AO-7, The Sleeping Beauty Smallsat.....	30
5.1	AO-7 Primary Mission (First Life).....	30
5.1.1	AO-7 & The Amateur Satellite Service.....	30
5.1.2	The Use of CodeStore	31
5.2	AO-7 - Support to Space Education	31
5.3	COSPAS/SARSAT Experiments	32
6.0	AO-7 In The “Sleeping Beauty” Phase	33
7.0	The Second Lifetime of AO-7	33
7.1	What Still Works and What Doesn’t?	33
7.2	Satellites and the Old Folks who Built Them	38
8.0	Engineering Outcomes Over 50 Years - A Summary.....	38
8.1	Radiation Dose	38
8.2	The Survival of Individual Piece Parts	39
8.3	Long Term Engineering Experiments - Back to the Photon Propeller	40
8.4	Orbit Perturbations of Higher SSOs	41
9.0	The Technological Relevance of a 50-Year-Old Space System	42
10.0	The Future for the Oldest Satellite Still Functioning.....	43
11.0	Acknowledgements	44
12.0	Afterthought	44
13.0	References	45

ABSTRACT

It has often been reported that the oldest satellites still working in space are, collectively, the JPL Space Probes Voyager 1 and Voyager 2. The Voyagers were both launched in 1977 to take advantage of the planetary alignment called, back then, the “Grand Tour”. This was the alignment of the outer planets, which allowed, using gravitational assist, both Voyagers to visit multiple planets each. Both missions were nothing short of spectacular and they still expand our imaginations. Their images changed the human vision of our solar system. But, are they really the oldest, still functional spacecraft in outer space? What if we include spacecraft that remained behind in Earth Orbit? Is it even believable to state that the oldest still working satellite in space wasn’t even designed or operated by NASA, USAF, ESA or any other space agency? What if it was stated that this satellite was designed by radio amateurs and the final assembly occurred in a basement laboratory not far from Goddard Space Flight Center? What if it was noted that 2024 is the 50th anniversary of this satellite, launched on 15 November 1974? And, as you will see (and hear) in this paper, the spacecraft, AMSAT-OSCAR-7 (AO-7) is still providing service to hundreds of radio operators around the world, as it has for a very, very long time. And, would you believe that the oldest satellite working around our planet is a SmallSat weighing 29 Kg?

The above, as nearly as we can determine, is all true and this is the amazing story of what made this possible and why this satellite is sometimes called the “Sleeping Beauty Satellite.” We describe here the story of how the mission was conceived, how radio amateurs from four countries worked together to develop a very complex spacecraft with quite a creative payload.

We want to explain the many successes of this communications satellite during its primary mission, and we want to surprise you with the extended mission, which continues to this day.

The technology employed by AO-7 was advanced and, in certain aspects, was ahead of the primary spacecraft it flew with (NOAA-4/ITOS-G). We ’ll tell that story, as well as summarizing other forthcoming special papers relating to the satellite’s orbit, power and communications systems and radiation exposure.

Time permitting, during the oral presentation of this paper, we will demonstrate the still- functional, robust, telemetry systems and communications transponders aboard AO-7. This is possible, as all these systems can be witnessed using only an audio feed. Much of the telemetry is provided by a very reliable Canadian-provided, 435 MHz beacon transmitter coupled to a novel circularly polarized antenna.

We would also like to invite any member of the audience to participate in using AO-7 to do their own experiments as AO-7 moves into the future. AO-7 has already lived longer than many of its designers and operators. It is just possible that it will outlast all of us. - Still in its 1450 km SSO, waiting for the next generation of SmallSat engineers to learn from what it can teach them.

1.0 Introduction

In beginning this paper, it is worth noting that the author has recently heard from colleagues, several comments, delivered via social media, which suggest that our thesis in the above abstract is flawed and the simple fact that the spacecraft we are reporting about here, AMSAT-OSCAR-7, may be older than the two JPL Voyager spacecraft is not relevant. AO-7 wasn't a real spacecraft like the Voyagers are. Some would use the term, "of dissimilar ethic" to put it another way. But, hold that thought! We'll get back to it!

Well, if we were to keep on this track, it would put us off to a bad start. Perhaps we shouldn't compare apples and oranges. What we'd like to do in this paper is tell you a long story about a well-loved piece of hardware, which was created by a group of enthusiastic space-loving young engineers looking for the opportunity to do something real in space. They came from many countries and backgrounds and for four years they worked together to create this 29 Kg object. They didn't have a lot of money. But, they had enough money to buy the essential items that couldn't be begged, borrowed or stolen. This is an account of an old small satellite, which defied the odds.

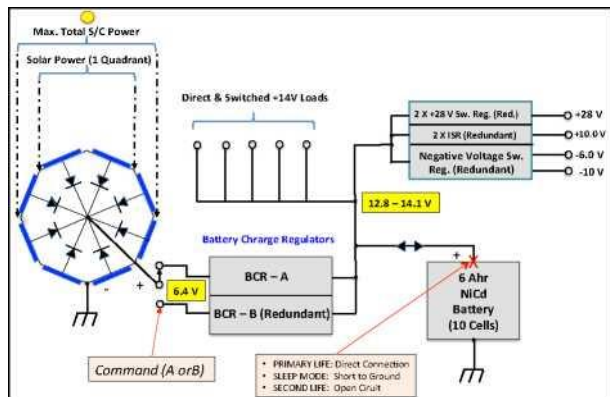

Fig. 1. Simplified Power Subsystem Block Diagram

There would be little argument that the satellite was a SmallSat. It weighed less than 50 Kg and was launched as a secondary payload. This spacecraft, in its on-orbit performance not only did everything its designers asked it to do, it proceeded to outlive the other two spacecraft that were launched with it (INTASAT and NOAA-4). AMSAT, the organization who developed the AO-7 mission, didn't have a lot of money so a lot of hardware was borrowed from NASA laboratories and other government labs. Such laboratories and other hiding places had components left over from earlier missions. Our team never got much pushback from

NASA or DoD employees, when we'd argued that putting such components back in space was a better place for them than the government excess property list. It can be noted that not every person who made us such a loan believed we would be successful in getting the hardware launched. The fact of the matter is most of the hardware worth launching - did get launched by us. It also didn't hurt that we were technologically eager, enthusiastic, young engineers that wanted to know absolutely everything about the device being requested of the donor. So, now, 50 years on, our secret is out. It turns out, and it is a pretty universal human trait: people admire other young people that want to do good things, especially if it happens to be with the hardware a particular engineer or technician designed themselves but, never got to fly.

1.1 Lucky AO-7

There are two sets of components, which fall into this category; they've made history because they did fly on AMSAT-OSCAR-7. Let's explain this.

1) One very exciting program that flew from NASA/GSFC was called Radio Astronomy Explorer (2). (RAE-2). This satellite did radio astronomy measurements from around the moon. This spacecraft used a standard NiCd battery design of the day, employing standard 6 AH cells. However, our understanding back then, these particular cells were procured from a local vendor and underwent different assembly procedures than were used by a vendor like Eagle-Pitcher (a vendor we were very familiar with). This battery is the star of our show for the story we're telling. The particular battery pack we were given was the engineering-test battery for the RAE-2 program. It had accumulated many hours working under load in the RAE-B ("B" before launch) functional and environmental test program, before it was removed and retired. This battery, unfortunately (but, also very fortunately - as we'll explain) became the primary battery for AO-7. NiCd battery cells, as they accumulate more cycles, begin to increase their series resistance. This causes the voltages of each cell in the battery pack to begin to sag under load. This behavior gets worse with the increasing number of duty cycles, especially with higher depth-of-drain. AO-7's battery did it's best for 6.5 years from launch and allowed the spacecraft to carry out every element of its mission requirements before it did what all NiCd batteries do: In mid-year 1981, each cell in the battery failed SHORT. This occurred over the months of June and July of that year - one cell after another. The spacecraft had failed, we thought, for good. The spacecraft team was not too upset about this apparent demise of

AO-7 as we had accomplished all of the goals of the program with this very popular spacecraft. Tens of thousands of radio amateurs had used the satellite and many specialized communications demonstrations had been carried out as well. We had even replaced AO-7 with a successor S/C, AO-8. What was not expected is, 21 years later, in mid-June of 2002, the satellite was heard again, first by a very loyal AO-7 user from the past. That seemed most appropriate. It was clear, after a careful assessment, that what had occurred in the spacecraft was one of the shorted NiCd cells had failed again but, this time, it failed OPEN. NiCd cells, simply stated, do not do that. We believe that something in the processing of these particular cells during their assembly caused a material defect, different from nominal NiCd technology that caused at least this one cell to fail open. NASA/GSFC's processing of this lot of cells had been, somehow, different. This may have been caused by a chemical reaction or a material change of some form. The cause of this change is certainly not known. However, when the battery pack went OPEN CIRCUIT, this allowed all of the loads in the spacecraft, via the Battery Charge Regulator, to be powered again. This included all of AO-7's payloads. (See Fig. 1). The spacecraft came back to life at that moment in mid-2002 and it has remained in operation since, without a battery, running only by means of solar array power - until now. There is no reason to believe, as we will discuss further, that this condition will not last well into the future. The spacecraft will have been in orbit for 50 years on 15 November 2024.

2) The second gift from NASA to AMSAT was a box of old solar panels found in the attic of Building 11 at GSFC. In this case, we didn't have to talk to any particular NASA/GSFC power engineer in order to obtain permission to use them. These cells had simply been abandoned by another very popular, but, earlier program, then already completed. This program was known as the Orbiting Geophysical Observatory (OGO). The particulars make this story more magical. In the box discovered were 16 brand new solar panel segments (in their original boxes - sealed and with desiccant still in place) and two panels of the same type but these had obviously been test articles. This was exactly the number we needed to build a 12-14 watt small satellite. But, there were no spares. The two additional engineering panels were more than handy. The design we selected, with these treasures in hand, was an 8-sided octagonal structure; just the right size for the program we had in mind. Fig. 2 shows what we came up with.

But, the panels were far more special than we realized. What we couldn't have known at the time; these panels were perfect for the long-lived high radiation (cumulative dose) mission that would be in our future. Three of the six OGO spacecraft were placed in orbits that were approximately 300 km X 148,000 km X 30° inclination. Hence, half of these spacecraft transitioned the Van Allen belts every orbit and were expected to accumulate a high radiation dosage. The panels we'd discovered were most likely from OGO-5, the last HEO spacecraft in the OGO series. These solar array panels had been especially processed to reduce their damage due to the increased cumulative radiation dose of high- energy protons and electrons. While most modern spacecraft designs would now use cover slides of increased thickness as the primary means of reducing power loss, this was not a free variable for these HEO missions. The launch vehicle was an old Thor-Agena. Launch mass was severely restricted given the available launch mass of the day, especially to an orbit with an apogee of 150,000 km! Thick Fused Silica cover slides are very heavy. NASA apparently had the solar panel vendor modify the cell substrate material to affect the improved radiation hardness of the panels. The exact method used is no longer known (although it



Figure-2: AO-7 Showing Its OGO Solar Panels

can likely be verified with more research). What can be reported here is that the array power still available is pretty amazing given the total dosage AO-7 has received (a fluence of approximately 2.5×10^{15} /cm²). For more details on this saga, see Sec. 8.1 below. But, it can be said, the AO-7 program was lucky-in-the-extreme to have been able to fly radiation hardened solar cells on what was a nominal LEO mission of the day.

1.2 This Has Been Going on for a Long Time

The stage should be set to begin to introduce our 50- year-old hardware. As the name of our satellite suggests, AO-7 was the seventh in a series of Amateur Satellites. If the reader is new to the world of small satellites, it may surprise you to know that the very first small satellite to be launched was OSCAR-1; launched in 1961. The satellite was built by a man named Lance Ginner (radio call sign K6GSJ). It was assembled in his garage in Los Altos, CA. Lance, a Lockheed employee, with many friends who, collectively, made up a non-profit organization called Project OSCAR (Orbiting Satellite Carrying Amateur Radio), managed to get the USAF to approve the inclusion of this “piggyback” spacecraft as 2nd stage ballast on the next available Corona mission. The launch vehicle used for each Corona spacecraft was also a Thor-Agena. By any measure we can determine, OSCAR-1 was the very first SmallSat. Sadly, Lance died last year, and with his passing ends the first era of small satellites. Project OSCAR managed to launch four spacecraft until their primary launch source went dry. That was in about 1966. OSCAR had demonstrated the value of “spare volume” in the “boot” of a rocket. So, DoD decided to use that space itself. It was 1969 before AMSAT (The Radio Amateur Satellite Corporation) was formed, and before our organization (also a 501(c)(3)) realized that NASA was a more likely candidate for launching secondary payloads than U.S. military vehicles. The advanced Thor-Agena, for those of you who may not know or remember, became DELTA and the Delta L/V became a NASA legend. As the sign said, it became the NASA workhorse.

As the interface between Project OSCAR and the still- evolving organization AMSAT was occurring, a new small satellite was built. And, it was even more unlikely than its predecessors to have succeeded. Students from the University of Melbourne in Australia built a small educational satellite (partly scientific in theme; partly inspired by amateur radio engineering) it was designed from books and lecture notes and built in basements in accordance with what these students *thought* a satellite should be like. It was a very good piece of work. It was fabricated and tested in Melbourne, Australia and then delivered to Project OSCAR in Sunnyvale, CA in 1967. Project OSCAR, despite valiant attempts, was unable to launch the spacecraft. AMSAT, as a new organization, decided, wisely (in this case), that it might be better to try to launch a nearly completed satellite rather than start by building a new one from scratch. We took on the task of refurbishing, testing and flying

what became Australis- OSCAR-5. It flew on a Delta 76. It was an important decision and one that SmallSat enthusiasts should be thankful for. It was this program that established the ground rules for what it meant to be QUALIFIED to fly a SmallSat. There are or will be other papers on this topic. However, as the program manager for that initiative as well as for AO-7, this author would like to note here: The efforts to get AO-5 qualified as a Delta payload and approved by NOAA, who had the primary spacecraft on that mission, and then by the NASA Administrator were SIGNIFICANT. The FCC and ITU authorizations for AO-5 by comparison, were far more easily accomplished. AO-5, accomplished many firsts:

- a) First Small Satellite to be launched by NASA (and Delta) for an external organization.
- b) First International Small Satellite Ever Launched
- c) First University Satellite Ever Launched
- d) First Command-able Small Satellite (demonstrated)
- e) First Use of the 29.5 MHz Amateur Radio Spectrum
- f) It achieved magnetic lock with its simple passive ACS system during its short lifetime. TLM verified the events involved. The satellite’s analog TLM system worked exceptionally well.

Because it was the first satellite handled by the then, young AMSAT organization, it was slightly more than exciting. This spacecraft had no solar panels; only an internal (primary) battery. It lasted 46 days in space and failed when the batteries were depleted. It was in a TIROS sun-synchronous orbit. In the early operational meteorological satellite days, these orbits were 14301460 km, circular, SSOs. AO-5 will be in orbit for a while now (approximately 10,000 years).

2.0 AO-7 Mission Concept & AMSAT- OSCAR-6

The Delta 76 launch was a free launch for AMSAT. NASA, in round numbers, spent about \$100K to modify the launch vehicle in order to accommodate AO-5 as a secondary payload. The cost to AMSAT was the approval by the NASA and NOAA Administrators. It did not hurt that John F. Clark, the NASA/GSFC Center Director and Jack Townsend, the Administrator of NOAA were both radio amateurs themselves. However, the Project Manager for TIROS-M, the primary person who needed to be sold on the idea, started our relationship by telling the author, "Well Jan, I liked your presentation very much but, my response to you regarding the approval for you to fly: It is No, Hell No or Never." He told me I could pick whichever of these responses I chose. That kind of response hits a 23-year-old pretty hard. But, with the support of the "Can-Do" Delta team, we turned that into a GO FOR LAUNCH from NOAA. It took about 9 months to do that. There is more to that story, but you'll have to catch up with the author for the rest of it.

If one small satellite was a good thing, then, surely, more would be better. That was the AMSAT expectation, with one successful mission under our belts. Our confidence grew, the organization grew and our reputation around NASA was getting better, as well. After all, many of us were NASA employees, to begin with. Our ability to "scrounge" much-needed specialty devices became well known around Goddard (see above). However, it wasn't just the piece parts that were important. NASA engineers to the time to explain to us how devices worked - often in detail.

The motivation from the onset was clear. We wanted a well-functioning, reliable communications satellite. LEO would do for a while but HEO or GEO missions were our aspirations, even in 1970. It seems perhaps odd that a collection of radio operators would find satellites so compelling but it's clear now why radio amateurs were the first to be successful at this venture. While this hobby is in a major way, about communicating, it has other facets too. It motivates individual to learn about electronics - and in detail. It motivates individuals to *build things*. So, if one takes these natural motivations, and then mix in some basic mechanical skills and then throw in a degree in physics and a job at NASA (or a job at other organizations such as COMSAT, COMSAT Labs, APL/John Hopkins, the Naval Research Labs, IBM, etc.) you can see the perfect mix of skill needed to build small space systems were at hand - in the

Washington, D.C. area. It also doesn't hurt that most radio amateurs are also (and have to be) familiar with the FCC and the ITU radio regulations. The big bonus was that several of our new members were FCC employees and some of us worked on a number of strategic ITU WARC Working Parties. This is the environment in which we found ourselves in 1971.

2.1 Experimenter's Meetings

Radio amateurs are naturally very international in their thinking. Early on, that is what fascinated so many people about this field of technology. Individuals being able to communicate via the ionosphere, long before telephony was a "thing" was exciting. The only way to talk to, say, Europe from the USA in 1935, was, practically speaking, by knowing a radio "ham" who could make the call. Amateur radio became a kind of international community.

By 1971, AMSAT had grown to encompass enthusiastic young engineers from Australia, Canada, Germany, France, Japan, and the United Kingdom, and several other hi-tech areas of the world. All of these individuals wanted to help; however, many also had some very good ideas. There were things they wanted to build. Without knowing how or why, we had truly attracted the best and brightest young minds from just about everywhere we could imagine. Amazingly, they all wanted to do the same thing: Build a real communications satellite - right now. And so, we did. We formed a working group, who met via amateur radio communications whenever we could. And, approximately quarterly, we would hold an Experimenter's Meeting. These meetings don't sound particularly interesting or important. Not everyone would come to Washington, DC where they were held. However, everyone would come at least once a year. At first these meetings were peer reviewed proposal exercises, where we sorted out "who would build what, and how." However, as the process proceeded and these became more formal, they became design reviews, pre-test reviews, operations planning meetings and eventually even pre-ship reviews. AMSAT was already emulating the organizational structure becoming apparent around us in the real aerospace environment. Again, most of us worked in that world. So, we merely brought the same toolkit into our hobby. That concept worked well.

We began to realize, however, as clever as we thought we were, time was an enemy. Spacecraft take time to come about. Surprise! The phrase, "young and foolish" comes to mind. It became clear

that while we had a great beginning on several projects, the sum of which would make a great communications spacecraft, we had more launch opportunities than we had time to build satellites to fill them. At this point, we made another very good decision. We decided we couldn't get enough of our "advanced mission" together fast enough. And, we could reduce the risk of the "big plan" by building a simpler test mission - a "protoflight" for testing most-but-not-all of the hardware that was to be the eventual real story - AMSAT-OSCAR-7. So, conceptually, AMSAT-OSCAR-6 was born in late 1971 and it was launched with ITOS-D (NOAA-2) in late 1972. In retrospect, this reduced-scope spacecraft from a designer/Program Manager's perspective encountered only one strategic event - and that event was life changing for this author. The spacecraft failed its proto-flight vibration test. We were only a week away from shipping AO-6 to Vandenberg when this happened. Have you ever redesigned and modified a flight spacecraft structure and then conducted a proto-flight vibration test and then, had it pass the test in seven days? That's what happened one late week in September of 1972. Never again, did the author ever come close to failing a vibration test. Every program I've ever worked on since has had a prototype structure that was tested to QUAL-levels before building any flight hardware. These future spacecraft have always passed that test. Lessons can and must be learned. This was my biggest. Jerry Burdette, the DPM-Technical for ITOS from Goddard was all over us when the AO-6 spacecraft arrived at WTR (now Vandenberg Space Force Center). Before the ITOS engineers let us mate AO-6 to the launch vehicle (about 30 cm away from the ITOS-D primary satellite) we had to take the spacecraft nearly apart and demonstrate our reinforcements to Jerry and all of the quality engineers on the NASA/NOAA team. Jerry let us fly. It all worked and AO-6 proved everything we'd hoped it would and much more. This we believe to be the first secondary payload (SmallSat) that flew in-proximity to its primary spacecraft. Prior to this time, secondary payloads were always placed in the aft end of the 2nd stage - in the "engine" compartment. This "proximity" story continues below.

3.0 The Detailed Design and Fabrication of a Complex Small Satellite

Experimenter's Meetings continued un-abated. We were learning from AO-6, now in orbit, about the hardware we had only dreamt of before. Now we had some hard data. We corrected our designs where we needed to; based on what AO-6 was telling us. It was at this epoch, when we found the

RAE-2 battery pack and the OGO-5 solar panels. This event created a turn in the road, particularly regarding our thoughts on the AO-7 structural design. We'd been carrying forward a rectangular solid structural design, based on some older (and much heavier) TIROS spare solar panels.

3.1 Comparative Models and Methods

We were excited about the new octagonal cylinder design we'd thought of, based on having taken possession of the 16 OGO panels. And, in making our decision, we looked to other smaller sized Goddard programs for inspiration. One program that caught our attention was the Explorer 45 program also known as S³ (Small Scientific Satellite). This spacecraft was a role model for us in many ways. It had a similar number of experiments (small from the standpoint of an Explorer of the day), It had a similar geometry to what we wanted to achieve, and it was, for NASA, a low-cost program. We copied everything we could, while keeping our own ideas fresh. See Figure 3.

Given our still recent AO-6 vibration test failure, we wanted to learn from this mistake. After completing the mechanical structure design, an octagonal cylinder, we immediately built a prototype mass engineering model. The spacecraft was mechanically centered around the aforementioned 10-cell NiCd battery pack. The electronics was divided into 16 modules (12 large and 4 small). These standardized modules force uniformity. S/C in the 1970s at NASA/GSFC were very modular. The modules slid into the structure frame on small rails and were then bolted in place. This concept was also "borrowed" from the Goddard IMP (International Monitoring Program). IMP-1 through 6 were our models for the module designs we came up with. We were able to find radio amateurs who owned and operated aluminum-machining shops. These volunteers donated the finished modules and the rail assembly; made to our design - at no cost to AMSAT.

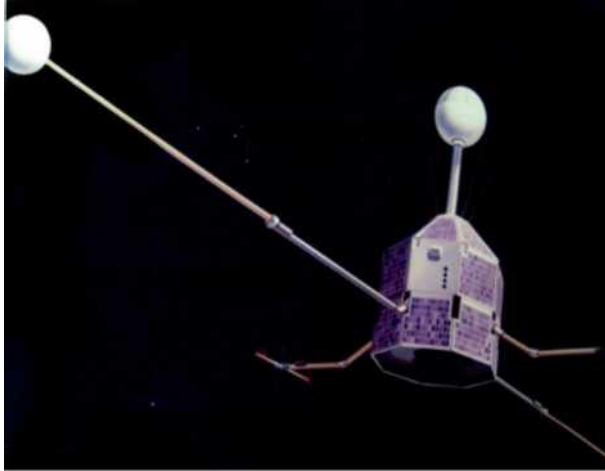

Figure 3: Explorer 45 - S³ Launched 15 Nov. 1971

At about this time, over in the Delta Program, news was heard that another secondary payload was looking for a launch opportunity. This payload was an International satellite; the very first satellite for Spain. The spacecraft was to be known as INTASAT and their project was looking for a launch in the same time frame as we were. NASA HQ was keen to support such an international opportunity, and the NASA Administrator immediately approved the program. For the first time in my life, I began to think about the meaning of the word *competition*. However, before I even had time to worry about the possibility we might have to stand down for another secondary payload, my, by now, good friend at the Delta Project, John Tomasello gave me a call to let me know there was going to be room for *three* on this upcoming ITOS-G launch! Relief! The INTASAT program team became “great mates.” We attended several secondary payload meetings together. We shared ideas. There was some strength in numbers to be had. Secondary payloaders unite! When we finally saw the INTASAT design, we realized that they even looked almost like we did - their spacecraft was the same size but, they were a 12-sided cylinder, compared to our 8 sides. Delta had wanted to fly two or more secondary payloads for a long time. Two secondary payloads was another FIRST for Delta. It was now everyone’s chance to fly!

3.2 Amateur Radio Experiments and Their Implementation

It is possible to think of the inventiveness, which occurred during this period (and, the ideas that were ultimately implemented in flight hardware) as being of two flavors:

a) Telecommunications Experiments - primarily using amateur radio frequencies and methods, yet

applicable to other telecom systems/satellites.

b) Spacecraft Technology Experiments - new ideas applicable to all future satellites, and especially small ones

It is worth noting here that the team of AO-7 experimenters was every bit as enthusiastic about exciting NASA missions (e.g., Surveyor Landing on the Moon) as they were about completing this amateur radio project. This could be said about all of us - to the last person. Spacecraft were exciting to us, not just Amateur Radio Spacecraft. Again, amateur radio was the vehicle which selected us. This hobby brought together; quickly, volunteers who were not only enthusiastic about building a spacecraft; they also had the skill set to do it. It was a form of natural selection, one might say. So, in describing them, we divide the experiments into these two categories.

3.2.1 The VHF/HF Transponder (Mode A)

This linear communications transponder was developed by Dr. Perry Klein (K3JTE). Perry was an original founder of AMSAT and its first President. This transponder concept had been completed in time for flight on AO-6 and so it was the *shooting star* for that spacecraft program. Indeed, this was to become the first long-lived communications payload to ever have flown on a small satellite. This transponder was built again for AO-7. There were some minor frequency adjustments made based on user feedback from AO-6. This transponder receives in a 100 kHz-wide passband in the 2M amateur frequency band (145.85-145.95 MHz) and the TX downlink is in the Amateur Radio 10M band (29.40-29.50 MHz). There is also a telemetry beacon transmitter at the downlink band edge (29.50 MHz). The output power of this transponder was about 2 Watts PEP. The beacon’s power level was set at about 50 mW. The G/T of the VHF receiver is on the order of -20 dB/K. The transponder is linear and the HPA is biased approximately Class AB_j. The receive antenna is a circularly polarized canted turnstile, while the downlink antenna is a proper length dipole antenna resonant on 29.5 MHz. This antenna was actually the first SmallSat antenna deployed using a pair of pyrotechnic devices, known as “reefing line cutters.” This deployment is another first. It is the first use of ICC Class 2 ordinance by any secondary payload, while on orbit. The antenna was deployed by a timer about 4 seconds after deployment of the spacecraft from the launcher. Richard Daniels (W4PUJ) fabricated the transponder in his “lab” at home. Dick not only built this particular transponder, he was our mechanical assembly technician for all of the AO-7

spacecraft. Dick's "day-job": he helped manage NASA financial matters at NASA-HQ. Dick also happened to be the AMSAT individual present when the NASA Administrator, James Fletcher signed the authorization to launch AO-7. He happily delivered that document to Perry Klein, who also designed this transponder. This transponder is still in use today on AO-7. In total, three AMSAT spacecraft carried one- each of these transponders (AO-6, AO-7 and AO-8).

3.2.2 The UHF/VHF Transponder (Mode B)

This transponder, by any measure, is the star of the show for AO-7 and it certainly deserves to be. This transponder was developed by Dr. Karl Meinzer (DJ4ZC) in partial fulfillment of the requirements for his PhD thesis. Karl lives in Marburg, Germany. In thinking about this, you should also realize that this transponder is still in use - nearly every day on the AO-7 spacecraft by many radio amateurs. So, Karl has a 50- year-old, still working, PhD thesis project!

In the space-flight world, it has been a long-term goal to continually improve the power efficiency of all communications satellites, not just those that transmit in the amateur satellite frequency bands. Users of amateur radio systems, even today, tend to utilize a spectrally efficient form of amplitude modulation known as single sideband (SSB). It was Dr. Meinzer's goal to develop a power efficient means to re-transmit an SSB signal. SSB suppresses the carrier of an AM signal and one of its two modulation sidebands. It is possible to transmit two forms of SSB then: USB = Upper Sideband and LSB = Lower Sideband. The receiving station must know which Sideband is being used for demodulation purposes. The residual sideband signal has approximately the same properties as a human voice. It has a typical peak-to-average power ratio of between 10-15 dB.

Amateur radio, in the HF bands evolved a channelization scheme, which we could call random frequency division multiple access. The random aspect to this "plan" is, that there are no channel boundaries. The multiplexing scheme is quite simple: if you "hear" someone on the "channel" you would like to use, then don't transmit on that frequency. This will cause interference to the receiving station if you were to pick that one. One simply moves in frequency until an empty spot is identified and then it is OK to try to transmit on the channel. In case someone is using the channel (you might not be able to hear one side of a two-sided conversation) then the pair of occupants of that channel will advise you very quickly. Then you must move again. Eventually,

everyone finds a location to use. This is a bit like birds finding a nesting area on a cliff somewhere on an island. So, this is RFDMA, for those who haven't experienced it.

An SSB signal, driven by the human voice, has a distribution, which looks a little bit like a Gaussian distribution, i.e. a high level around zero and it falls off with increasingly positive or negative voltage. But, contrary to a Gaussian, the signal does not exceed a certain level in amplitude, which is caused by the finite power with which the voice is produced. Now comes the essential point: An SSB signal, in fact any signal with multiple frequency content, can be seen as composed of various sine-waves and cosine-waves (orthogonal signal components) - which also can be described by an absolute magnitude and a phase. The amplitude then is the absolute values of these sine and cosine waves combined. If the sine and cosine levels have a Gaussian distribution, it is fairly easy to show that the resulting amplitude is Rayleigh distributed. The Rayleigh distribution is thus caused by the fact that we have two dimensions (orthogonally situated), each of which is Gaussian distributed. These sine and cosine components are summed in amplitude and thus, result in the Rayleigh distribution.

This Rayleigh distribution can be terminated on the lower amplitude side, such that the peak-to-average power ratio is about 7 dB. So, that is one parameter we need in order to properly design our HPA for this transponder. The second key parameter is, in order to provide a "high fidelity" SSB channel; the *peak* S/N should be in the range of 16 to 20 dB. Such a system would have, then, an average S/N of about 10 dB or slightly higher. What we'd really like is an S/(N+I) of say, 20 dB (peak). The dominant source of "I" (interference) is intermodulation. Intermodulation happens when the peak of the sum of all the signals gets too big and the amplifier starts to saturate because of these peaks. This kind of interference spreads over the entire band and ultimately creates a background "noise" level, and "intermod" will frequently be larger than the white noise of the transponder. But, in any case, the S/(N+I) we are seeking here requires an IMR (signal-to intermodulation ratio) of about 20 dB. This is the 2nd key specification for this transponder.

What Karl wanted to do then, is provide the highest peak power possible for this transponder, given a statistical, amplitude signal ensemble that is Rayleigh distributed with a Peak-to-Average Power Ratio (PAPR) of about 7 dB and a transponder IMR, which was to be at least 20 dB down.

We recall that our solar panels could provide about 1214 watts peak in the sun. Counting the eclipse, our average power budget is cut back to about 10 watts. If we allow about 1 watt for other spacecraft electronics then the HPA might have about 9 watts of available power on a sustained basis. If the amplifier consuming this power were, say, 35% efficient then the average power of the HPA would be about 3.2 watts. And, with a Rayleigh with a PAPR of 7 dB, the peak power would be 15.7 watts.

But, we have a problem here. In order to keep the intermodulation value down and in order to prevent the amplifier from saturating on peaks of the Rayleigh distribution too often, it is necessary to “back off” the drive power to the final amplifier. And, a sad reality of the physics of this situation is that reducing the operating point of the amplifier, reduces its DC-to-RF efficiency. That’s the parameter we most dearly care about.

Enter Dr. Meinzer’s PhD Thesis: ^{1a} An American engineer, Leonard Kahn, in the 1950’s had devised a scheme to linearize an AM broadcast transmitter, by dividing the HPA into two channels. The first channel contains only the phase information of the incoming signal ensemble (in this case about 15 SSB signals in a 50 kHz bandwidth). As the phase information can be amplified at *constant envelope* it can be amplified quite efficiently using a Class-C amplifier. The amplitude envelope for the 15 SSB channels contains the Rayleigh distributed amplitude-modulated spectrum with a PAPR of 7 dB. The amplifier, which performed this task, had to, itself, be linear. And Class B is the most efficient choice for this task. This amplifier, containing only the baseband components, can be relatively efficient (say 60-70%). At the end of the process, the Class B envelope channel output AM modulates the phase channel, thus recombining the two components. This fortunately, yields the original input amplitude and phase spectrum but, now amplified more efficiently. Kahn, in his paper on this topic, referred to this method as Envelope Elimination and Restoration.^{1b} However, Kahn built prototypes of the EER apparatus using only vacuum tubes. He had never implemented a solid-state version. Further, Kahn had not ever worked with a multicarrier signal group and perhaps most importantly, he had not characterized the bandwidth requirements of the Envelope channel. A key determination of Karl’s thesis was establishing this bandwidth requirement. For our signal structure passing through the EER system Karl empirically and analytically determined that the Class-B Envelop amplifier required a minimum bandwidth

of 3.0 times the input signal ensemble and a better requirement value for such a system would have a bandwidth of 5.0 times the input spectra. There was much circuitry required to support the transponder. For one, a dual AGC system helped maintain the 7 dB PAPR by setting both the peak power level and then the average power level of the signal as it entered the final amplifier chain. The transponder, which was dual conversion, converted the passband at 432.125-432.175 MHz to 145.975-145.925. As the ordering of these numbers suggests, the transponder mixing scheme inverts the passband. So, if a user uplinks a LSB signal, it comes down as USB. Also, a signal at the top of the uplink passband, appears at the bottom of the downlink passband. Indeed, this was confusing at first, for the users, who had never experienced this kind of inversion. However, the design was well motivated. The Doppler effect of signals via such an amateur radio transponder, have to be dealt with manually, given the equipment readily available. An inverting transponder subtracts the downlink Doppler from the uplink Doppler, instead of adding it. This makes reception of the downlink signal more straightforward.

Let’s return again to the power budget discussion above. We had concluded that the available DC power to the transponder was about 9 watts. The transponder Karl came up with was about 28% efficient (for just the EER portion of the HPA) and this matched the power available at about 9 watts. That, of course, means that the average power of the UHF/VHF Transponder was about 1.6 watts and the peak output power (called PEP: Peak Envelope Power) was 8.0 watts. The overall efficiency of the UHF/VHF transponder was about 18%. This includes the entire receiver and IF components. The IMR specification achieved by this transponder was 27 dB_r. This is an impressive value for any linear amplifier in anyone’s satellite.

This EER transponder motivated many more projects using methods other than EER in order to synthesize similar high efficiency, linear HPAs for more and better transponders. Karl’s total “bag of tricks” ultimately became known as HELAPS = High Efficiency Linear Amplification via Parametric Synthesis. Combined amplifiers with power efficiencies as high as 40% at S- band have been achieved using HELAPS. These amplifiers have certainly been used in the greater aerospace industry; however, digital methods of transmitting voice and non-voice signals have been subsequently developed. And, some of these techniques do not require such a high PAPR. In such cases, linear amplification becomes less

important. However, all FDMA systems, exhibit Rayleigh or Rayleigh-link amplitude effects. So, HELAPS remains relevant in today's aerospace environment.

3.2.3 The 435 MHz Beacon Transmitter

During this time frame AMSAT wasn't just building spacecraft. We participated extensively and, we might say, aggressively in the preparatory work associated with the ITU 1972 WARC (World Administrative Radio Conference). Our members actually participated in the WARC itself, held in Geneva during October- November of that year. The outcome of this effort was the creation of a new satellite service for the world: The Radio Amateur Satellite Service. By means of a new ITU footnote [FN 5.2.8.2; now ITU FN 664], this new service was given the opportunity to use five (5) new frequency bands on a secondary basis. Other bands have since been added on either a primary or a secondary basis. Many of you reading this paper have benefitted from this most valuable asset. By now over 600 small satellites, built mostly by universities, have used amateur radio spectrum by means of a form of licensing, which approves small satellites to use Amateur Satellite spectrum on an experimental basis, under certain circumstances. This would not be possible today had AMSAT not pursued the creation of this new service at the ITU, back in 1972.

AMSAT was very keen to begin to use these valuable resources as soon as we could. A team of Canadian radio amateurs who were very anxious to implement a

UHF beacon experiment on AO-7 realized the first real opportunity. Canada had been involved with AMSAT programs as early as the Australis-OSCAR-5 mission. A small group of Canadian radio amateurs became very interested in commanding AO-6 and they became command operations specialists for that spacecraft and then for AO-7, when it was launched. The leader of this group was Larry Kaser (VE3QB). On AO-6 we were able to get a simple 435.1 MHz beacon going. AMSAT refurbished an old telemetry transmitter in time for that mission. It worked well. However, the first serious independent beacon effort was mounted by Larry and his team, mostly from Ottawa. The 435.1 MHz beacon occupied one of our large modules. It transmitted in two modes: on-off keying, and FSK. The on-off mode was used for transmitting CW (Morse Code) telemetry and the FSK mode was used to transmit 850 Hz shift RTTY (50 baud standard) telemetry. These two telemetry encoders are addressed in 3.2.5 and 3.2.6 below. This transmitter was an exceptional piece of work.

It was one module that never gave us any problems during integration. The transmitter overall efficiency was better than 25%. It had a power output of 320-400 mW, depending on battery voltage. It was used extensively during AO-7's operational lifetime (FIRST LIFE) and it is the most stable transmitter (and easiest to use to demonstrate the satellite's continued performance) of all of the payloads during the satellite's SECOND LIFETIME. This transmitter will definitely be demonstrated during this year's conference. This telemetry beacon could be commanded ON/OFF during Mode D and would accept either Morse ON/OFF or FSK keying as required.

3.2.4 The 2304 MHz Beacon Transmitter

The story about this particular experiment, among the many comprising the AO-7 mission, doesn't have a happy ending. And, it is a project that demonstrates the "bite" which the international regulatory process can have on even a program like ours. This beacon was well-under construction at the time of the aforementioned 1972 WARC conference. There had been (and there still is) an S-band allocation to the Amateur Radio Service starting at 2300-2350 MHz. Amateurs had found this band particularly interesting for doing "moon-bounce" communications. The frequency of choice for these operations was 2304.0 MHz. AMSAT believed this would be an excellent frequency for our first microwave project. A group of radio amateur from the San Bernardino Microwave Society in California, led by Dick Kolbly, (K6HIJ) designed, from scratch, a 100 mW beacon transmitter. It was another great piece of work. This component also occupied one of our large modules in AO-7. It was fundamentally a CW transmitter, however, it carried a CMOS logic board, which transmitted in Morse, "HI" (a greeting and a standard frame sync that had, by then become a trademark of the OSCAR program). The HI keying was then followed by thirty seconds of continuous carrier, used for tracking purposes. "Tracking" in this case was not so casual for the users. At 2304 MHz the Doppler shift on an overhead pass was as large as ± 55 kHz. Typical amateur receivers use bandpass filters as narrow as 80 Hz for receiving low power narrowband signals. So, tracking was not a trivial exercise, just in order to follow the fast-moving carrier. The module also contained a 30-minute digital timer, which would turn the transmitter OFF, in case it had been turned on and, for some reason the command station was unable, at the end of the pass, to turn it OFF.

This great effort by Dick and his team was

complemented by another member group of our evergrowing AMSAT team. We needed a better-than-average antenna for this beacon. It turned out, one of the RF engineers at RCA- Astro Electronics Division, Walter Maxwell (W2DU) had developed a series of quadrifilar helix antennas for the ITOS series of satellites. Recall that ITOS-G (NOAA-4) was the primary satellite for AO-7's upcoming launch. ITOS used these X/2 quadrifilar helix antennas for both L- band and S-band downlink activities. Walter was able to modify one of the spare 2200 MHz ITOS antennas to work at 2300 MHz, with some considerable effort, and these antenna modifications and the hardware were funded by RCA-AED as their contribution to our program. This antenna has an omni-directional pattern (with a bit of gain on-boresight: 4 dBi) and is circularly polarized with an excellent axial ratio over its full one hemisphere of coverage. I felt privileged to have been able to work on this hardware with these two gifted experimenter groups. Altogether, this was a wonderful team effort!

Despite the hard work on this part of our project, in this single instance, the new footnote we had managed to get through the ITU did not work in our favor. The footnote had moved the S-band Amateur Radio Satellite allocation up from 2300-2350 MHz to 2400-2450 MHz. As this allocation came into being after the date when our hardware could be changed in frequency, changing that hardware was not an option. Our only option was to request a waiver from the FCC to transmit on 2304.0 MHz. We noted to the Commission, that the EIRP was very low, our emission was extraordinarily narrowband and we had a positive control mechanism via our ON/OFF timer. Despite our best efforts and a final request to consider the payload as only experimental (we had noted we could cease operations if any interference was detected) the FCC denied our application. Thus, our first microwave beacon transmitter was still-borne. It was launched in perfect working order; however, it was never switched ON. I'm certain there is a lesson learned here somewhere but, someone else, other than this author, should recite it. Perhaps someone from the FCC or the ITU will have a different opinion. The 2304 MHz beacon was a wonderful experience for our team but the experiments never got their reward. I'm sure all readers can relate to this story.

3.2.5 The Morse Code Telemetry System

There is something about Morse Code and modern times that don't go together. Ignoring its historical importance in telegraphy, generally, it's impact on

the shipping industry and its role in the two World Wars, it has other positive attributes as will be explained. However, and I get this all the time; the author does know how old it is and how slow it is. There is little doubt it is slow. Its speed is measured in *words per minute*. I believe, to coin a word, it is the very "antisymbol" of the modern digital age. So, if it is mentioned that AMSAT looked forward to one development more than most others, that was our Morse Code Telemetry Encoder, - this author might even lose some credibility in reporting this. What is such a thing doing on a spacecraft, the reader might ask?

Let's think about Morse in another way. In addition to a few spacecraft and the pursuit of a WRC radio allocation, AMSAT was also busy developing an educational curriculum. We thought it would be quite exciting to allow grade-school-to-high-school students the opportunity to understand the basics of a spacecraft. Not by reading about it in a book, rather by using a real spacecraft - in class. One of our members, Dr. Marty Davidoff, (K2UBC) decided to write a curriculum at the secondary education level. He received a grant to write it from DOE. *The Satellite Experimenters Handbook* ² was distributed by the ARRL and AMSAT to anyone who might want to teach others about spacecraft technology. The book especially targeted secondary school educators. Key among the concepts was the idea of giving a teacher, who may or may not be a radio amateur, the information necessary to assemble a receiving system, which could act as a student demonstration tool in school. This receiver and antenna would allow a class to "receive and decode" telemetry. This process, then, required the students to think through some orbital mechanics, the technology of antennas and receivers, and finally, the principles of demodulation and decoding. Along the way TLM multiplexing, A/D conversion and number scaling get introduced. All this works fine, since receivers were in pretty good supply in the mid-1970s. However, hardware for demodulation and decoding telemetry was not. This is where Morse came in. In the US alone, several million individuals in the 1970s knew Morse because they had to; it was a part of their job. One hundred thousand more radio amateurs had to pass an exam; part of which was learning Morse at between 5 and 20 WPM. So, there were many who could train young people who didn't yet have that skill. But, just the numbers, 0-9, in Morse can be learned in 10 minutes by just about anyone. You'll get the chance during our demonstration yourself. And, so it is a perfect tool for any 8th grader! Hence, all that is needed for this lecture was (and still is), a dipole antenna (or a small 3- element yagi - like a TV antenna), some coax cable, a radio

receiver and a room-full of teen-age brains. The latter component is, of course, the telemetry decoding apparatus (that is the part between each student's two ears).

Our Morse Code Telemetry Encoder System was designed and fabricated by John Goode (W5CAY). John was from the DFW area in Texas. This concept was his experimental contribution to AO-6 and AO-7. You will recall here, these satellites were built in 1971/74. Intel invented the 8-bit microprocessor in 1974. Early microcomputers were not available until 1976 at the earliest. The word Apple was still a fruit and Microsoft didn't yet exist. This unit was built in one of our small modules. It used fixed logic: 34 ICs, which were +10V CMOS (RCA CD4000-AD series). 1 LM108A operational amplifier was used for the A/D converter. This little box, using CMOS was amazingly efficient. It required 2 ma of current at 10V DC from the power bus. That is a whopping 20 mW. This TLM encoder had 24 analog input channels organized as shown in Figure 4:

TLM John Fox (W0LER)	TLM Scott Wiessenmeyer (K7WDO)
1181:42 UTC	01:43 UTC
15 Nov 1974	21 Feb 2024
HI HI	HI HI
182 134 195 188	100 182 1157 177
296 201 201 268	294 200 282 254
383 373 344 350	379 324 360 357
454 451 456 456	487 494 403 408
546 501 550 551	532 504 540 555
601 657 601 651	600 660 602 651

Figure 4: M.C. TLM Encoder Data Format (Frame #1: 1974; Frame #2: 2024)

The 24 channels organized in 4 columns and 6 rows, were divided, basically, into current, voltage and temperature channels. All were scaled to a 1.0 V full-scale input to the A/D converter. The encoder produced decimal values and was organized into two Morse characters between 0 and 99. The first number of each word is a digit giving the row number of the datum. This reduces the ambiguity of where in the frame the encoder was; in case the decoding person got a bit lost. Each

channel could be scaled by setting the ratio of two resistors ($R_f/R_{i,n}$) on the input operational amplifier. This amplifier was located externally to the encoder on these earlier satellites, however, in later TLM systems, the R_m resistor became a part of the multiplexer itself. For students it was very hard to make life simpler, given the whole concept of a digital telemetry system. Note, the decoding, whether one has a bias toward Morse or not, is digital, not analog. But, a pen, paper and a brain are the decoding equipment, not a computer and a printer or plotter. At the beginning of each frame of data are the Morse letters HI (.....), sent twice. This serves as a human "frame synchronization word", as a greeting from the spacecraft and as an identifier, just in case you didn't know you were listening to an OSCAR spacecraft. If you wanted to plot, say, the battery voltage over a pass, then a great exercise for the student is to plot successive values of channel 3A on good ole graph paper. OK, Excel works fine too, *etc.*^ nowadays. Below in 3.3.3 we'll explain how this telemetry system was used widely by amateur experiments to observe AO-7's spin rate - yet another experiment, as you will see.

3.2.6 The RTTY Telemetry System

The closest thing the amateur radio community had as standardized digital, "high speed" communications in the 1970's was a Teletype writer. A subset of radio amateurs had introduced proper FSK Teletype into the HF bands. This was accepted by coordinating groups within the Amateur Radio Service such as the ARRL and the IARU and by the FCC and other administrations worldwide. Standards were not entirely uniform. The US standard for RTTY was 55 bps (baud), whereas in much of the rest of the world, the data rate standard was 50 baud. Recalling again, we were designing hardware with ICs but, before the microprocessor, a data standard like BPSK, 8-bit framed telemetry would have been a much harder standard to support as the decoding equipment, would not have fit well inside amateur operator budgets. But, for a real enthusiast, RTTY did. So, the 50 bps international data rate standard was selected for the 2nd AMSAT telemetry standard. The Australian, Peter Hammer (VK3ZPI) one of the original Australis- OSCAR-5 team and a University of Melbourne graduate, had long been enthusiastic about creating both telemetry and command capabilities for the new satellite system. Edwin Schoell (VK3BDS) assisted him in the circuit design and construction. Their RTTY telemetry system was not for the faint-of-heart. It contained more than 100 CMOS integrated circuits and analog operational amplifier ICs as well. This

unit required two of our large size modules to accommodate this much hardware. The RTTY TLM Encoder sampled 60 analog channels and 2 octal channels based on telemetry points all around the spacecraft. This was our workhorse housekeeping telemetry. The output format, as it would appear on paper from a Teletype machine is as shown in Figure 5. In fact, these are two real RTTY frames recorded; one in 2009 and one earlier in 2024. So, this second frame is a real, nearly current, telemetry frame from a soon-to-be 50-year-old satellite.

```

3 MAR 2009 (ZL2BX) -New Zealand
-00367-01762-02891 -03896-04764-05010-06750-07905-00000-09810 -10263-11770-
12337-13714-14603-15937-16419-17397-10000-19149 -20484-21729-22902-23906-
24796-25010-26704-27883-20000-29834 -30259-31000-32000-33483-34000-35221 -
36244-37283-30000-39251 -40501 -41708-42912-43916-44823-45010-46710-47917-
40000-49866 -50254-51766-52330-53009-54000-55000-56000-57000-50000-59854 -
00567-02547-00567-02547-00567-02547-00567-02547-00567-02547 -00567-02547-
00567-02547-00567-02547-00567-02547-00567-02547

5 JAN 2024 (K7WDO) - Oregon, U S A.
-00808-01687-02649-03626-04669-05427-06685-07642-00000-09687 -10469-11604-
12469-13425-14427-15000-16826-17826-10000-19622 -20889-21686-22667-23609-
24680-25423-26804-27660-20000-29686 -30000-31000-32000-33824-34000-35628-
36643-37665-30000-39662 -40782-41804-42662-43624-44661 -45426-46688-47684-
40000-49689 -50000-51604-52488-53409-54000-55000-56000-57000-50000-59627 -
01455-04707-01455-04707-01455-04707-01455-04107-01455-04707 -01455-04707-
01455-04707-01455-04707-01455-04707-01455-04707

```

Figure 5: RTTY TLM Encoder Data Format

The data format for this encoder is reasonably obvious. Each analog data value is 3 decimal digits (so values range from 000-999). The two-digit channel number precedes each analog value. The analog values are organized in 6 rows with 10 words per row and 5 digits per word. The first six rows are then followed by two rows of status information encoded in octal format. The two 5-character words alternate 10 times over the last two rows of the frame. The first of these octal words is a long-term (273 day) clock. The clock advances once per 96 minutes (or about once per orbit). The 2nd octal word gives the status of the command decoder registers identifying the last command received. The first word allows a kind of S/C long-term clock and reference system and the 2nd parameter allows a command station to know if the command sent was correctly received. Given the broad scope of this paper, it was decided not to publish here the identification of the telemetry channels for either telemetry encoder or the calibration equations; however, this information is available from the authors upon request. Alternatively, they can be found at: <https://www.amsat.org/wordpress/wp-content/uploads/2018/10/AMSAT-OSCAR-7-Guide.pdf>

The RTTY TLM system had a 2nd major mode. The idea for this second mode, we can say, humbly, was a really good idea we learned from NASA. This 2nd mode is a dwell mode. This allows for a particular channel to be sampled repeatedly so that faster, continuous data can be taken. It was believed that this would assist in any diagnosis of a spacecraft malfunction that might be caught by more rapid measurement of particular telemetry data. Figure 6 is such a dwell event. This was observed on 17 December 2022, showing that the RTTY dwell feature was still working at that time. We note that an additional digit as a LSD is being added in several cases, but not all.

```

-03157
 9
-031579
 9
-031579
 9
-031579
 9
-031579
 9
-03157
 9

```

Figure 6: RTTY TLM in the DWELL MODE

We are investigating this behavior. We haven't seen it before; the sampling itself and the CR and LF are occurring correctly in the encoding sequence, however, we can't, as yet, account for the appearance of an extra digit, in some instances. This may, indeed, be one very limited case where radiation has affected CMOS logic states. We cannot confirm this situation at this point.

3.2.7 CodeStore

There has always been a fascination among radio amateur in digital modes of communications. In thinking about the timeframe - where this spacecraft sits in electronic history - it is all too easy to forget, we're at T-3 years and counting from the first 8-bit microprocessor. AMSAT, and this author, in particular, were keenly interested in NASA's "Data Collection Platform" experiments on TIROS and NIMBUS. The notion of Packet Communications was still nearly 10 years into the future at this juncture. Our experiment team wanted to demonstrate that we could store data at- will on a spacecraft in transit across the sky and then, download it at another location. We already wanted to demonstrate non-real-time digital communications to ourselves and to the world. So, with the energy we had left, we developed one last, simple communications experiment. That

experiment, thinking in retrospect, wasn't the best it could have been. However, it can be argued, it was simple and it proved our resolve. And, it did lead to far more ambitious packetized, store-and-forward data satellites in our future. The entry in 1972 on AO-6 and, then again, in 1974 on-board AO-7 was a demonstration experiment we called *CodeStore*. It probably wasn't the best design choice possible at the time but we chose the command frequency for the uplink. This meant we didn't have to implement yet another receiver. However, this made the experiment far less general than it could have been. AMSAT did not want to share the knowledge of the command frequency and codes with anyone who didn't have a need to know them. Thus, CodeStore (it's uplink in particular) was not an experiment that was shared with everyone, as were the communications transponders described above. It could, realistically, only be used by authorized command stations. We had hoped for a universal store-and-forward demonstration. What, in fact, was created was a broadcast tool. And in that regard, CodeStore was very successful. What was left in AO-7's array of modules, was one, last small module. CodeStore was the brainchild of and was designed and fabricated by John Goode (W5CAY), who also provided the M.C. Telemetry Encoder. In one small module, he housed an AFSK decoding system, which allowed uplink data to be clocked into a "long" shift register. To be precise, the shift register contained 896 bits. This was done with the memory ICs of the day. What one could manage then, was 14 ICs each containing 64 bits of serial data storage. The contents of the shift register was sequentially downlinked (FIFO) to the selected beacon, when we commanded CodeStore to the RUN mode. Now you'll notice that this number of bits is divisible by 8 and so one might have expected that we would have downlinked a message of 112 8-bit words. No, this was 1974 and so we downlinked a Morse Code message. The idea, once again being, more individuals can copy a broadcast message if they don't need specialized decoding equipment. So, once again we relied on the computer between the two ears of each user in order to decode the CodeStore message. No one can deny that we could have made a better go of it, if the notion of a remote terminal digital communications goal had remained pure. It did not. However, the utilization of this message system was handled with some *class*, it can be said. CodeStore's output, which was made available to the beacons on both the Mode A and B transponders, was a kind of matrix option. The command system allowed either TLM encoder OR CodeStore to "modulate" either the Mode A beacon, the Mode B beacon or the 435.1 MHz beacon. So, regardless of which transmitter was on,

CodeStore was an option for use. CodeStore's use evolved. Ultimately, its highest value was discovered to be to store the spacecraft's (then) NORAD TLEs as well as any critical AO-7 operating schedule modifications, which might be of importance to the users. Putting this into perspective, CodeStore was available in time for launch and use on AO-6. So, users were already expecting this feature, which appeared regularly on the beacon transmitters, once AO-7 appeared in orbit.

3.2.8 The Command System

It is clear that a spacecraft of this category needed a command system. However, AMSAT feared the loss of control of our satellite as much as, today, a bank fears hackers stealing banking details. We've never published the details of our command system. It is not that we trust anyone more than we used to. What we're sharing here, is done simply because we want to reveal what small satellites could do in 1974 - without microprocessors. All that is being disclosed here was done with analog circuitry and discrete logic. The AO-7 command system was designed and developed by Peter Hammer who also built the RTTY TLM Encoder. It was Peter, in fact, who was the first person to suggest to us, that we use RCA CD4000-AD series CMOS IC's as our logic-of-choice for AO-6 and AO-7. This was single-handedly the best technical decision AMSAT ever made! There is more to come on this topic. Each CMD system occupied one large module in AO-7. AO-6 had only a single command decoder, which allowed Peter and AMSAT to evaluate its performance as soon as possible. AO-7, however, had two redundant Command Decoder modules. Each decoder could demodulate 35 discrete "pulse" commands. The two decoders were used in full redundancy, with each of the 35 commands terminated in the same location for both decoders. Of course, this wasn't absolutely necessary however, redundancy, at this stage of small satellite technology was still being "evaluated". After all, NASA always used redundant command elements. Who were we to doubt the significance of this form of redundancy? We went even a bit further. Among the 35 commands available on each decoder, we made sure that the most critical commands (those that allowed us to select the 4 operating MODES: A, B, C and D) were themselves redundant on each decoder. As we will explain next, these critical commands were even backed up by the ECL (Experiment Control Logic), which was our "discrete flight computer". This unit with its robust timer cycled the modes of operation every 24 hours, just in case the two command decoders or the

command receivers (also redundant) failed. In the end, we hardly used the command system at all for mode control. The ECL did all the work.

The command decoders received FSK tones in a tone- sequential manner. A command enable tone (different for each decoder) was followed by 7 command bits. Three of these bits must be a logical “1” and four must be a logical “0” for the command to be valid. One can do the math easily enough (or use your fingers), the number of ways in seven bits to organize three “1s” and 4 “0s” is 35. A final pulse passes the 7 bits to a decoding matrix and an 80-100 ms pulse, 10V in amplitude is generated on 1 of 35 output CMOS driver devices. A suitable wiring harness was utilized to distribute these pulses to their appropriate destinations. As you would expect, the redundancy required an OR gate at the receiving end for each command.

3.2.9 The Experiment Control Logic (ECL)

Perhaps we’ve overstated the case for such a spacecraft needing a microprocessor, when there were none to be had. But, we weren’t alone in needing one. We had been paying attention to NASA and others (DoD, ARPA, NOAA) who were building “real” spacecraft. They too had every need for a flight computer. And people like Don Lokerson at NASA/GSFC³ were designing and developing discrete logic systems that were, all-but-in-name, flight computers. Many scientific spacecraft were passing binary sequences of instructions from a central “controller” to each experiment. These were generated by extended messages that were pre-programmed on the ground, uplinked, and stored in serial memories. Each experiment, of a dozen or more, might be required to execute lengthy messages containing data settings and control states that might be required in order to set operating states in these instruments. In some instances, hundreds of thousands of gates or shift register states could be involved. AMSAT could not compete yet, with this class of discrete logic. Our entire controller had to be contained in the space of one of our small modules. Karl Meinzer, of Germany, designed the ECL. It was left to Jan King W3GEY of AMSAT to implement the logic and package the design. With some help, the analog threshold detection circuitry was added to the overall design. Karl’s digital design was a proper logic design and he used real Boolean algebra to minimize the gate count. Karl’s concept was bread- boarded fully and various battery charge/discharge “triggers” were added as we learned more about NiCd battery technology; sometimes even from AO-6, already in orbit. The final design consisted of 27 RCA CMOS CD4000-

AD series ICs and a small number of operational amplifiers, used mostly as comparators. The flow diagram we came up with is given in Fig. 7.

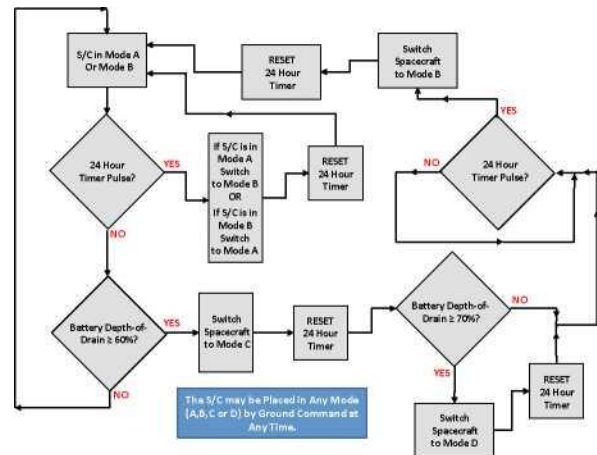

Figure 7: ECL Logic Flow Diagram

It may well be worth explaining some of the rationale for our choices. It is certain the reader will understand the flow diagram. At this time in our history, it was believed we had at least two classes of users: advanced users who had VHF and UHF experience (remember: it is 1974) and we had new users who were more familiar with operating radios in the HF bands. We did not want to prejudice either type of user. Therefore, we gave equal time to the operation of the VHF-to-HF transponder (Mode A) and to the operation of the UHF - to-VHF transponder (Mode B). The decision was made (and it was fateful) to use a 24-hour crystal-controlled clock and a D flip-flop to implement this functionality. The spacecraft then would operate in the A-B-A-B- and so on mode, indefinitely (NOTE: and it has done so, more or less, for 50 years). If a first under-voltage condition is reached at 60% battery depth-of-drain (DoD), the ECL puts the S/C into a reduced power mode of the UHF-to-VHF transponder, cutting the S/C total power by about 'A. This mode is simply called MODE C. If the spacecraft still continued to discharge (and still doesn't exhibit a positive power budget) then the ECL will trigger a recharge mode when 70% DoD is reached: MODE D. However, MODE D still allows the use of the 435.1 MHz beacon and any of the devices which could send that beacon useful data. That was either of the TLM encoders or Code Store. However, these modes must be implemented by ground command. Indeed, it is possible to focus on TLM or CodeStore and run the 435.1 beacon just for the intended purpose of taking telemetry or transmitting CodeStore data. During AO-7's primary lifetime, this was occasionally done to allow more focus on these two important aspects of

spacecraft management. Thus, sometimes there was time out for the telemetry enthusiasts too. After 24 hours in MODE D, the timer always came back to MODE B. And, MODE B, as you'll see from the logic flow, is a rather more preferred mode. This turns out to be an important reason why AO-7 in its SECOND LIFE has been so successful. In fact, the ECL as it is designed, makes it really hard to keep AO-7 OFF. The spacecraft "wants" to be in Mode B with the UHF/VHF transponder ON.

3.2.10 The VHF/UHF Antenna Combiner

The antenna combiner was not so much an amateur radio experiment as it was an invention of necessity. The reader should feel free to imagine this design as a kind of thought experiment as we go through it. If you do it this way, you can see what we went through on this particular bit of magic. This design was much like solving a puzzle. Our spacecraft has a beautiful symmetry about it and it had one obvious surface readily available for a VHF and/or UHF antenna "array". The ADCS design essentially required an Omni-directional antenna pattern at VHF and UHF and it was very desirable for the antenna to produce circular polarization. Our payloads, as described above, had the following inputs and outputs and worked in these modes (remember: Mode A and B are mutually exclusive):

- a) UHF RX - Mode B Only
- b) VHF TX - Mode B Only
- c) VHF RX - Mode A Only
- d) UHF TX (Beacon) - Mode A and Mode D Only

A suitable antenna, which was very popular on NASA/GSFC spacecraft, appeared like it would satisfy our pattern and polarization requirements. Again, we copied the idea from NASA. This antenna is known as a Canted Turnstile. This antenna is essentially a crossed dipole, fed in quadrature to give circular polarization. It can be mounted to a single surface, if desired. Such an antenna gives a good Omni pattern and has no nulls, although polarizations swap between the upper and the lower hemisphere. This antenna can be implemented using 4 monopoles oriented as shown in Figure 8. The four elements lie on the surface of a cone.

The cone angle at the vertex can be varied in the design; however, the cone angle affects the axial ratio of the antenna. We used a cone angle of 70°.

This particular parameter is not a significant issue in our case, given the user community's ability to adapt to polarization changes.

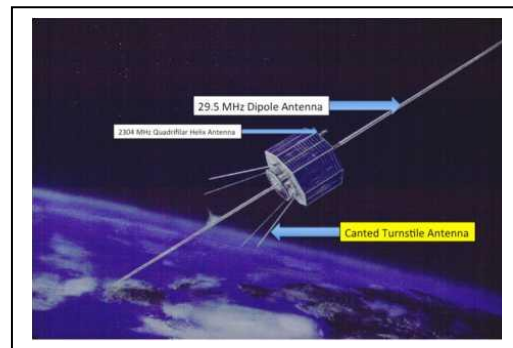

Figure 8: AO-7 Spacecraft Antennas – Highlighting the VHF/UHF Canted Turnstile

The design exercise then, is, there can only be one such antenna on the spacecraft and we have four inputs/outputs at UHF and VHF that want to share that antenna. How is this done with minimum effort in the combining process? There is one more magic trick that can be used to help us sort out the best way to do the combining. And, that trick works almost exclusively because this is an amateur radio satellite. Let's explain this concept. Unlike almost all other radio services authorized by the ITU, which transmit and receive from space, most of the radio amateur frequency bands are *harmonically* related. In particular the two bands being used here are harmonically related. How does that help? See Fig. 9.

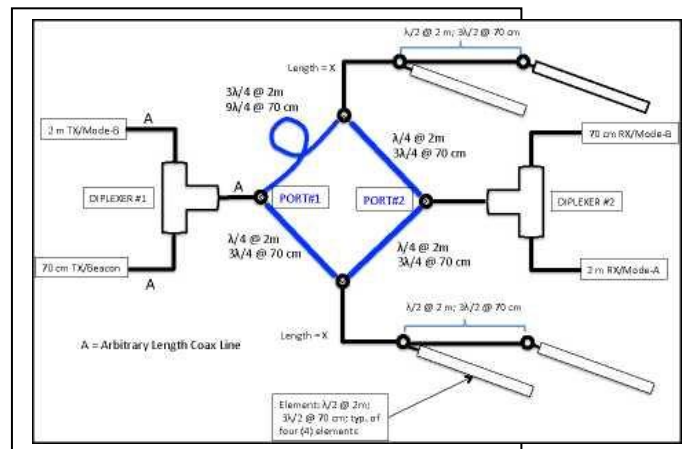

Figure 9: The AO-7 VHF/UHF Antenna Combiner Concept Using a 90 Coax Hybrid

The 3rd harmonic of our 2M band (145.9 MHz) lies within the amateur satellite band at 70 cm (437.7 MHz). This allows the Canted Turnstile to work at its 3rd harmonic (in UHF) as well as at its

fundamental frequency (in VHF). The pattern, it turns out, is also acceptable in the UHF band. Further, the 90° hybrid used to produce the correct phasing at each of the input ports, also works at the 3rd harmonic frequency. Hence, the 90° hybrid produces the appropriate nulls at the opposition port, as it must, at both sets of frequencies.

For those who haven't been through how a 90° hybrid works, here is a chance to learn it. While such a combiner doesn't have to be built this way, AO-7's hybrid was fabricated from eight (8) pieces of critical length coax cable. The hybrid ring is formed from 3 lines that are XIA in length and one that is $3XIA$. X is the wavelength at the operating frequency at 2 meters (146 MHz approximately). You need to know that a XIA length will cause a phase change through that cable of 90° . At the 3rd harmonic frequency, the wavelength relationship is $3XI A$. That corresponds to a 270° phase shift through the same cable. At the fundamental frequency ($2M=VHF$) we now observe that if the power from Port #1 splits equally and 1/2 of the power goes around each side of the hybrid, when the power arrives at Port #2, the two components are exactly out of phase and the two cancel. Now, if the reader does the math; at the harmonic frequency, you will learn that at the 3rd harmonic, the two ports are again out-of-phase (different by 180°) but, the polarization at the other two ports will be, again 90° out of phase, but, the other way around. This means the polarization of the antenna at VHF will be the opposite of the polarization at UHF. Also remember that the polarizations will again change when the satellites are in the Northern Hemisphere vs. the Southern Hemisphere due to the passive magnetic ADCS. These four cables forming the hybrid are of critical length.

The two cables labeled "X" are also critical in length. The length is arbitrary; however, the two cables must be identical in phase delay. The remaining two cables are XU in length at VHF and $3XI2$ in length at UHF. This keeps the two sides of each "dipole" out of phase by 180° as they must be, however, at UHF the wave goes through 540° of phase shift but, that is equal to 180° of phase shift so, this still keeps the phase difference at 180° , even at UHF. These two cables are also of critical length. So, all conditions have been satisfied for the signal phasing to work at both frequency bands into the single, now VHF/UHF common antenna. If you notice, each antenna port advances by 90° from the last port as you go around the azimuth of the satellite and the power splits up properly.

We're almost there, but here comes the puzzle. You

will notice that there are two T-shaped devices at the inputs to Port #1 and Port #2. The T devices are diplexer filters, used at each of these locations. Now, given 4 devices that can feed these two dipoles, which inputs feed into which dipoles and why? With some thought you'll realize there are four combinations of how we could assign these TX and RX devices to the 4 input/output ports. But, only one of these choices is appropriate and they are the ones given here. We leave it as an exercise to the reader to explain why the other choices are worse, however, we will argue for the choice we made of this particular option. Now please pay close attention to Figure 9. We note that for Hybrid #1, the 2M, Mode B TX is never ON when the 435 MHz (70 cm) beacon is ON. Still, a simple diplexerlike pair of bandpass filters isolates them. Similarly, over on Port #2, the 432 MHz, Mode B (70 cm) RX is never ON, when the 145 MHz, Mode A (2M) RX is ON. However, this is of no consequence, since both units are receivers in any case. Now we look across the hybrid at the crossover cases for interference. If the 2M, 145 MHz TX-Mode B is ON, it can pass power through Diplexer #1 and through Port #1. The energy from this TX then arrives at Port #2 via two paths. Due to the hybrid phasing, the power from this TX is nulled at Port #2. The isolation of a coax hybrid like this, if it well designed, is approximately 20 dB. So, the power from the 2M TX-Mode B is 20 dB down when it arrives at Hybrid #2. This remaining power will pass, unattenuated through Diplexer #2 to the 2M RX (Mode A). However, Mode A is OFF when Mode B is ON. We note, the 20 dB of attenuation from the hybrid is adequate to prevent the power from the 2M TX doing damage to the unpowered Mode A RX. There is also a 70 cm (Mode B) RX attached to the Diplexer #2 filter, and that particular receiver is the active input side of the Mode B repeater, which is currently ON. The filter must be sufficiently good to attenuate the TX so that this 70 cm (432 MHz) receiver is not desensitized by the residual energy from the 2M TX. This is the most demanding case for this antenna combiner.

We're just about there. We consider the case of the 70 cm (435 MHz) beacon transmitter emission in Mode A or D, passing through Diplexer #1, Port #1 and then being attenuated at Port #2 by about 20 dB. This attenuated signal arrives, not further attenuated by Diplexer #2 at the 70 cm (432 MHz) RX for Mode B. However, Mode B is OFF when Mode A or D is ON. So, the power must be attenuated enough by the hybrid so that this RX is not damaged by the 70 cm beacon emission. This depends largely on the attenuation of the hybrid. The last case is the 2M - Mode A RX, which is

active whenever the 70 cm beacon is transmitting. So, the attenuation of Diplexer #2 at 2M (145 MHz) must be sufficient so that there is no desensitization of this receiver from this 70 cm transmission. This path is critical because it is also the primary path for the command receiver, especially during the recharge mode (Mode D). All of these cases, having been studied, suggested the quality of the filters in the two diplexers was not in the category of *superior*! 60-70 dB of isolation from these filters was found to be adequate, after design calculations were carried out.

The antenna combiner hardware was also designed and fabricated by Karl Meinzer and his team in Germany. It had a special position, in a custom module located near the top surface (+Z) of the spacecraft, although the antenna was actually located on the bottom surface (- Z). The antenna (four “tape measure” blades) was configured symmetrically around the attach fitting of the spacecraft.

3.3 Amateur Space Experiments and Their Implementation

We wanted to demonstrate several principles, common to larger spacecraft, however, on a smaller scale. We will explain this class of experimentation next. These are a part of the story that didn’t get the flashy attention of the transponders or even, the ultimate attention of humble CodeStore. But, there are some firsts here. And, some of them are significant in the larger aerospace context. They should be given a proper disclosure now. Our AO-7 Experimenters were equally enthusiastic about the synthesis of these interesting non-radio amateur contributions to the evolution of small space.

3.3.1 The Battery Charge Regulator (BCR)

We need to do a bit of stage setting here first. The OGO solar panels, as noted, were a technology gift we could not ignore. However, they did create one difficulty, which was taken in stride. In the 1970’s, solar panel voltages, even in NASA designs, tended to be matched to the battery voltage, which was, in turn would set the required bus voltage. So, 28 V was a good number back then. This avoided the need for boost regulation, generally. Solar arrays could literally be connected to the battery. However, AMSAT found itself with 6.4 V solar panels and a 12V battery. This particularly made our team quite nervous, given our unfamiliarity with input regulators. However, a boost regulator was in order. Karl Meinzer, on a trip to the U.S., designed one in the author’s living room. Within a few weeks Karl’s team in Germany had a working

breadboard of this conceptual design. And, once this was fully developed, we realized this made our array voltage choice independent of the nominal battery voltage - even for future designs. Battery cell suppliers did not recommend this approach. This required closer control of battery voltage as well as temperature compensation. This was the starting point then, for AMSAT’s battery charging concept. It was driven by the necessity associated with “what we could get our hands on.” But, it ended up being a long-term advantage for all our small satellites.

Small satellite enthusiasts are (and they should be) consumed by a desire not to waste power and to increase the efficiency of everything around them. That is a good thing. General aviation pilots never leave a meter of runway behind them, when they start their takeoff. A good SmallSat engineer never wastes a milliwatt. The principle is the same. Any switching regulators with efficiencies under 90% were not acceptable. If you don’t need a very regulated voltage, just use the battery. That regulation process is 100% efficient. We needed a power supply to optimally charge the battery. We called it a BCR; simply, Battery Charge Regulator. We believe this was, at this time, a new term. While it is not so important, we believe AMSAT brought this term into use with AO-7. Much more important than this acronym is the principle of Peak Power Tracking. This technique had not been in use before AO-7 and the method used in this spacecraft was more unique still. Let’s explain this. Everyone has seen the classic I-V curve for a solar cell or a series/parallel string of the same. Figure 10 is an annotated version of the AO-7 array. This is for a 1 Quadrant solar array. That is 2 of 8 facets of cells or 4 OGO solar panels.

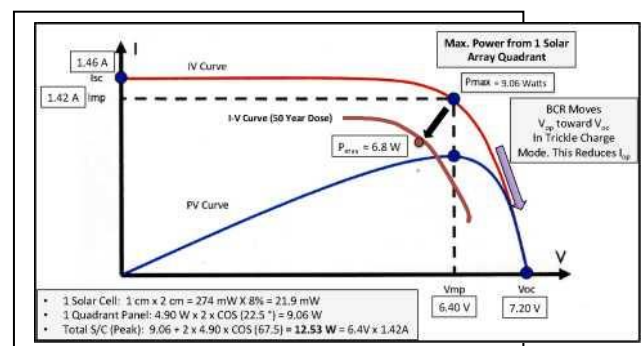

Figure 10: AO-7 Solar Cell I-V Characteristic (for One Solar Array Quadrant)

It is well known that the maximum power will be generated from a solar array when the load is adjusted so the operating point (in current and

voltage) is driven to the “knee” of this curve. This point is frequently referred to as P_{max} . The peak power from the array occurs at this point. Our BCR was designed, using analog methods only, in order to seek out P_{max} . This is a little harder than one might first imagine. P_{max} changes in voltage and current with both temperature and cumulative radiation effects. So, repeated sampling around P_{max} is necessary in order to find the proper location. This allows for optimum charging. There is, however, another important task for a BCR. That is the requirement to stop the charging when the battery is at full capacity. NiCd technology, in fact, allows for approximately a 2.5% of (C) capacity trickle charge rate without damage to the cells. In our case $C=6$ AH and $0.025 \times 6.0 = 150$ ma. Reviewing Fig. 9 again, there are two ways we can reduce the charging power by adjusting the load away from P_{max} . One means, and the more commonly used, is to reduce the voltage (at nearly constant current) to a safe power value. However, this doesn't reduce the current. Alternatively, (and not intuitively) we can increase the operating voltage from the array. Because of the I-V curve, this very quickly reduces the current from the array. The voltage continues to be increased until the current reduces to the required 150 ma. The AO-7 BCR reduced the power from the arrays by INCREASING the operating voltage of the arrays and this REDUCED the current being supplied to the battery cells. The BCR was stopped at approximately 100-150 ma of trickle charge current. This is a bit of inverted logic if one is used to Ohm's Law.

The AO-7 BCR was designed by Karl Meinzer (DJ4ZC) and was fabricated in Germany. The BCR occupied one of our large modules and the unit was fully redundant. There is no means to auto-switch between the two redundant regulators. The only means to swap BCRs is via ground command. During AO-7's primary lifetime (FIRST LIFE) the decision not to autoswitch was a good one. That is the case because the battery could sustain spacecraft operations for many hours-to-days after a BCR failure, allowing sufficient time for command station action. However, in AO-7's SECOND LIFE, the situation is more critical, since the BCR is also up-converting the array voltage from 6.4 volts (nominal) to about 14 volts. 13-14 V is the old battery operating voltage but it is also the primary bus voltage for all loads in the spacecraft. Now, since at least one battery cell has failed completely OPEN, the BCR is still sourcing this output voltage of about 13-14 volts to all of the loads but, no longer to the NiCd battery. The open circuit means the battery no longer exists. So now,

there is no battery backup and if the BCR were to fail, there would be no supply to the spacecraft loads at all. As long as the BCR works as it is, AO-7 can live on. It is best, most likely, to NOT command AO-7 to swap the BCRs anymore. There is now no battery backup should the alternate BCR not be functional. There would be no second chance to swap back.

3.3.2 The Photon Propeller; A Passive Player in Our System

When one considers the number of disciplines to be mastered when building a space vehicle there is bound to be at least one technology area weaker than the others. And, in our case, for the team designing and building AO-7 (and early SmallSats more generally) that weakness was, arguably, Attitude Determination and Control (ADCS). We didn't ignore this design domain to be sure. But, we didn't come up with a HELAPS-like solution to our attitude control system either. One could argue, with omni-directional antennas and solar cells just about everywhere, we didn't need to score highly in this design category. However, the truth is, this was just not the forte of any of our team, over the dozen or so countries that were participating in the Amateur Satellite Service in the 1970's. Project Australis - good ole' Australis- OSCAR-5 showed us the way. The Australians used a Passive Magnetic Attitude Stabilization System (PMAS) in order to stabilize that spacecraft.

The concept starts with a polar orbit. NOTE: A SSO is close enough. The key components are:

- 1) One ALNECO-5 bar magnet.
- 2) Some form of high-loss magnetic material. We used a particular form of iron rod, which caused a high hysteresis loss.
- 3) Some device then must be added to the satellite, which prevents the satellite spin rate from decaying to zero. This device is our story here.

The stabilization system is completely simple and it is completely passive. Noting about it requires deployment and there are no moving components. The bar magnet can easily be made strong enough to generate a static dipole moment in the spacecraft. For AO-7, given its symmetry, we implemented the spacecraft's magnetic dipole using 4 rather small ALNICO-5 magnets. They produced a dipole moment of approximately 100,000 pole-cm for the spacecraft. Another more familiar unit for dipole moment is $1.26E-4$ Weber-meters. This moment completely overwhelms any residual dipole field in

the spacecraft that may result from unintended (or ignored) current loops or residual pieces of magnetic material that might have been overlooked during materials selection. Such a magnetic array will capture the magnetic field within a few days. And the spacecraft dipole axis, (in our case the Z-axis) simply follows the Earth's dipole field. The initial release (or "tip-off") from the launch vehicle, in our case, was expected to impart a slow rotation of somewhere between 0.1 to 2 RPM. This is caused simply because the separation spring(s) from the release system don't push exactly through the center-of-gravity of the spacecraft. When the bar magnet locks the spacecraft to the Earth dipole, the residual angular moment from the separation event is translated to an angular rate about the dipole axis. It should be noted that the Earth's field in polar orbit simply produces two rotations of the spacecraft dipole axis (in our case this is a rotation of the Z-axis) in one orbit. So, to summarize, the Z-axis rotates in inertial space, twice per orbit and there is a residual spin ABOUT the Z-axis, which remains from the angular momentum imparted at separation. This rate about Z can be damped, and in our case, this was accomplished by means of the hysteresis rods. These rods cause a loss in the residual rotation energy by dissipating it via a hysteresis damping mechanism in the rods. In effect, angular energy is converted to heat via the rods. The result of this damping is a reduction in the spin rate about Z. This spin rate would approach zero in a decaying exponential way if we hadn't added some means of adding in some angular momentum about Z. Realize we'd witnessed this behavior with AO-5 and AO-6 because we'd used such a PMASS system in both spacecraft.

You'll have to imagine the excitement at one of our Experimenter's Meetings when, once again, Dr. Karl Meinzer showed us all his calculations, which demonstrated; one could use the four Canted Turnstile VHF/UHF antenna elements as a propeller to spin the spacecraft about the Z-axis. The antenna elements were approximately flat blades - in actual fact, they were made from fancy non-magnetic stainless steel tape measure material. And, since they are already in the general configuration of a propeller; if they are painted; one side black and the other side white, a differential torque will be created when this whole arrangement is exposed to the sun. This differential torque acts to spin up the spacecraft body. And, yes, this torque is adequate to do real "work" given the relatively small moment of inertia of the spacecraft body. In this scenario, the spacecraft spins up the satellite, however, this torque eventually comes into competition with the breaking torque being offered by the hysteresis rods. So, where would these two

forces come into equilibrium and at what spin rate would this occur? If the spin rate were too high, the angular momentum would begin to overcome the gravitational force producing the lock to the Earth dipole. However, if it was too slow, the spacecraft temperature gradient from the sun side to the anti-sun side of the spacecraft could get too large. Karl was careful with his calculations.

And, it wasn't the photon pressure that was the hard part of the estimation. We were having more difficulty estimating the damping of angular momentum by the hysteresis rods. I recall Karl's final estimate of the spin rate about Z to be bounded by 10 minutes/rotation on the high side and 30 minutes per rotation on the low side. We now have to jump ahead; so, this discussion can be closed out. When AO-7 launched it took approximately 3-4 days for the magnets to lock to the Earth dipole. The original angular moment resulted in a spin rate about Z of approximately 3 minutes/rotation. What happened next, is best shown in Figure 11. While we could improve the quality of this plot using a dozen computer "apps," we thought it might be more nostalgic to provide the reader with the original, hand-made plot, which so clearly demonstrates the photon propeller was working. And, it still works during AO-7's SECOND LIFE. But, that is yet another small story. You'll notice from the plot, the spin rate came into equilibrium between the photon torque and the hysteresis breaking about 6 months (2000 orbits) after launch. The spin rate, after that epoch, coincides with the annual plot of the eclipse duration (when the % sun goes up, the spin rate goes up (the period of rotation goes down)). The spin period is a maximum in July and a minimum in November of each year. And we noticed the spacecraft spins up after exiting eclipse and is at its fastest rate just upon entering eclipse. Hence the photon propeller can be seen to work by simply comparing the spin rate on ascending and descending node passes (about 12 hours separated). Therefore, the photon propeller has shown itself to be effective, even on the short term - during a fraction of an orbit.

The 16-minute average spin rate around the Z was just right to wash out the thermal gradient that would have been seen if no spin had been introduced. So, as always, Dr. Meinzer's estimate was right on track. The spacecraft outcome split the difference, based on his original estimate. A photon propeller is a real thing. And, you can use it to control the spin rate on your small satellite.

We actually haven't explained how the spin rate was measured via telemetry. This was accomplished by plotting the solar panel current

from any one of the X or Y panels over time. If the time between two maxima from any of these panels is measured, the spacecraft rotation period can be determined. Since a typical pass lasted for 25-30 minutes and the longest spin rate was 18 minutes, the measurement could be done with precision. One must remember this went on for years and the plotting was done by hand. So, this process was a lot of work. One particular radio amateur, John Fox WOLER from Minneapolis, MN made AO-7's spin period his dedicated task for the 6 years of the (primary) FIRST LIFE of AO-7.

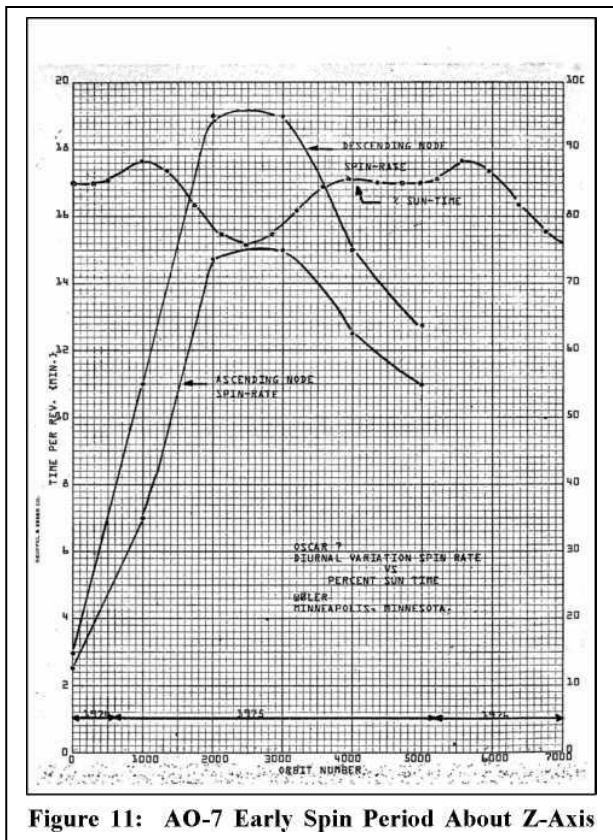

Figure 11: AO-7 Early Spin Period About Z-Axis

[NOTE: “Spin Rate” on this plot should actually be Spin Period].

3.3.3 Radiation; Total Dose; CMOS and Other Devices

Nothing in our career has been more consistent than the FACT that in-orbit radiation exists. And, it is a factor for all space missions. Devices change; methods of modeling radiation change; but the threat of cumulative dose and single event effects to all spacecraft mission remains. The AO-6 and AO-7 spacecraft missions emerged at an important epoch relative to the long story

about radiation effects on spacecraft. In 1972, the first Complementary Symmetry Metal Oxide Semiconductors were introduced, at least so far as spacecraft were concerned. RCA, Summerville, NJ, USA was THE pioneer of what that company called COSMOS integrated circuits. RCA's name wasn't to last. The technology ended up being known as CMOS, as we all know. CMOS was a breakthrough in digital device technology. Because of its complementary symmetry MOS topology (two MOS devices in series - one of the pair is ON and the other one OFF) each circuit draws power only during its actual switching event, as the two MOS transistors swap state. This result ends up with each integrated circuit only consuming microwatts of power. This means an entire AO-7 module of CMOS devices typically drew only milliwatts of power. The devices first introduced by RCA in their 4000 series CMOS line of parts were $V_{dd} = 10\text{ V}$; dual-in-line and ceramic. Such parts were given the suffix AD. In addition, these devices were very tolerant to supply voltage swing. Any supply voltage between 5 and 10 V could be used. Perhaps, one limitation of this family of digital parts, at the time of the design phase of AO-6 & AO-7 was the number of functional types available to the designer. At this time the RCA CMOS parts list ran from CD4000AD to CD4024AD. So, there were only 25 choices to select from. Despite the limited choice of components, the options available seemed almost custom-selected for satellite use. One case in point, was the CD4016-AD. This device, the author's favorite, contained 4 analog switches. Each switch had an analog input; an analog output and a switch enable line. By turning on the enable line, the analog value at the input was passed to the output. Thus, one IC can multiplex 4 channels of analog telemetry. Describing this part also gives the reader an idea of the level of integration of these devices. Using 14 to 18 pin DIP devices, allows 2 to 4 gates or, 6 inverters to be incorporated into one IC. With this level of functionality, the CMOS devices were distributed among AO-7's 12 large and 4 small modules as in Table 1.0. Some modules, of course, only contained analog, RF and other solid-state devices. Discrete transistors were numerous.

Before getting to the radiation analysis issues so obviously needed in this story, we need to summarize the “pedigree” of the RCA CMOS devices we used. The ICs “procured” by AMSAT for both AO-6 and AO-7 (same lot) were, in fact, donated by RCA to AMSAT but, they were also screened to MIL-STD- 883B and YES, we did receive the full documentation from RCA, Summerville for each device and YES, each device was serialized. And, NO, AMSAT did not further screen the parts nor did we select the parts based on

the detailed measured capability of each device.

S/C Unit:	# CMOS ICs	# Analog ICs	Bus Current @10 V
ECL	27	4	1.5 ma
CMD Decoder (X2)	28 X 2 = 56	None	2.5 ma Each Decoder
M.C. TLM	34	2	1.9 ma
RTTY TLM	106	2	10 ma
2304 Beacon	8	None	1.0 ma
ISR	1	1	0.2 ma
TOTAL	232	9	Not ON Simultaneously

Table 1.0: CMOS IC Count for AO-7

What the author can say, as the one who selected the devices: all parameters measured far exceeded the requirements of the RCA specifications. In particular, the output drive current of these devices was typically only specified to be a few milliamps. The measured values, from the RCA data were well in excess of 5 milliamps (typical). So, it was clear that these devices were really robust examples of this technology. This lot of ICs, however, was *not* RAD HARD. And, these ICs couldn't be procured RAD HARD back then. The radiation hardening process for CMOS in this era was still evolving. AMSAT did, later on, use RAD HARD RCA 1802 COSMAC microprocessors, so we are aware now, of what was, back then, waiting in our future - but, that is yet another story. At this epoch such technology was still a dream away.

We are now at the point in our story that, we believe many have been waiting to hear about - the Radiation Environment for AO-7. Given this high SSO, there were many skeptics at NASA/GSFC regarding the wisdom of using this family of CMOS parts as primary mission devices. Most of the readers will be generally familiar with the ESA on-line software called SPENVIS. One could have died for the availability of such a program in 1972-74. In this era, mini-computers were not even readily available. Mainframe computers were available for NASA employees to use. And NASA/GSFC had developed a radiation model, including protons, electrons and even including

Bremsstrahlung effects, for both cumulative dose analysis and solar array degradation analysis. The “keeper-of-the-keys” to this wondrous bit of software at NASA was a grand old fellow, Greek in origin: E. Stassinopolous (the longest name in the GSFC phone book). “Stass” (as he was called for short) and the author became good colleagues. Very few other individuals approached Stass and ask for free data runs as we did. I recall we may have even come up with a real R&D “charge number” for this work at some point. To sit and learn from an expert about this environment was one of the best of GSFC experiences. After some review of the anticipated ITOS SSO, Stass eventually rendered his opinion that, in this orbit, the new RCA CMOS devices would likely last for approximately 3 years. The original radiation model runs carried out by Stass on GSFC’s only IBM 360-95 (shared with the Apollo program, by the way) are no longer in existence. Sadly, neither is Stass. However, Figure 12 shows what Stass was basing his judgment upon.

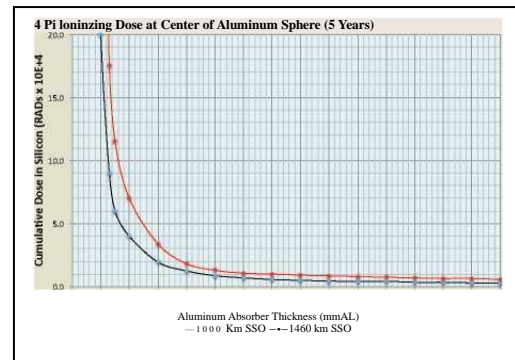

Figure 12: Dose Depth Curve; 5 Years for 1460 km SSO

This dose depth curve, originally derived from a SPENVIS run, shows the cumulative dose received after 5 years in a 1460 km SSO (red) and by comparison, for a 1000 km SSO (blue), as a function of shielding behind a particular thickness of Aluminum. Have a look at the dose received, particularly, by the small modules, which are well shielded. These units are located above the battery and have at least 4 mm of AL shielding in all other directions. The plot suggests these parts will have received about 20 kRAD (Si) of cumulative dosage at 5 years exposure. The large modules (like the Command Decoder

s) have less shielding - perhaps 2 to 3 mm AL equivalent. These devices will have received more like 80 kRADs (Si) of cumulative dose. It is important to note, single event effects were essentially unknown back in 1972-74 and they are probably irrelevant here, give the device level- of-

integration available and given our Vdd of 10V. So, Stass felt that 50 kRAD was about what these parts could take and so, his 3-year estimate is supported by this more modern SPENVIS-like analysis. Unless the reader wants to read ahead, the final assessment of how well AO-7 survived is left until Section 8.1 of this paper. However, we'll say at this point that AO-7 did not die or suffer from radiation damage during its primary lifetime of 6.5 years. Nor did it show any signs of doing so. We want to summarize, in case there are those who thought, perhaps AMSAT would not have been interested in the radiation scenario for AO-6 and AO-7; nothing could be farther from the truth. We considered radiation to be one of the grand aerospace experiences to be understood. Certainly, we cared about this environment so far as this SmallSat was concerned and we struggled with the 3-year prognosis given by NASA, however, we hoped for better luck! It is about all we could do at that time, except - calculate.

3.3.4 Piece Parts Reliability Experiments

The reader might also anticipate that piece parts quality was of little or no interest, given the Amateur Radio aspects of this SmallSat. Once again we'd like to set the record straight if there are those who might believe this. Perhaps no other discussion took more time than the discussions about where to come up with piece parts for these two missions. To be fair, this topic was learned from scratch starting with AO-5 in 1970. And, there was a steep learning curve that followed. The larger set of devices used were, indeed, the RCA CMOS devices and those parts were both clean (low-outgassing) and high reliability. An interesting part of the story comes from our lessons learned in the NASA supply store. The author started his career in the Test and Evaluation Division, located in Bldg. 7 at GSFC. This facility contained a vast array of environmental test chambers and facilities. It was not a bad place to learn about the functional and environmental testing of all satellites (even small ones). Building 7 had a store that carried thousands of items but, most interestingly ALL sorts of electronic components: resistors, capacitors, diodes, transistors and all sorts of terminals of one kind or another. All one had to do to get the part was put down a job cost accounting number, your name and the code of your work location (mine was 325.1). You might imagine we used this capability all the time as a source for our piece parts for AO-7. Actually, one of the destinations for AMSAT's actual outlay of cash for these early satellites was for small piece parts like resistors, capacitors, transistors and diodes. We got good at ordering them from regional vendors.

However, where the parts store came in was the lessons it taught us about quality. Parts were sorted by JAN, JANTX and JANTXV. Now, I'll not explain the meaning of these "gobbledy-gook" letters except to say that more letters equals higher reliability and more screening. I think even NASA employees hazed over when it came to this. To make things easier for everyone to understand the level of quality of these parts, a color system was introduced. If the parts were less than JAN (essentially, had no qualification) they didn't have any small dot on them. If they were JAN, they had a tiny yellow dot of paint on the part. If they were JANTX, they had a similar green dot. One never found JANTXV parts in the parts store. They were reserved for the real high-end programs (like OGO or ITOS as explained above). But, AMSAT could buy them if we wanted to spend that much money. While we got the odd JANTX parts from the storeroom, when we couldn't find them in stock from our vendors, we'd make sure they had a green dot. But, what the parts store taught us was *the_system*. And, that we never forgot. We remember using a few 2N2222A-JANTX transistors from the parts store for AO-7. It was perhaps NASA's favorite NPN transistor for Goddard spacecraft!

Non-US Piece Parts: While we'd learned a lot about how the U.S. government identifies and meets environmental and cleanliness requirements for piece parts we had no idea how to deal with such matters when it came to similar and largely European piece parts. We did see a few Australian native parts; however, they were a rarity. We used a few high-quality carbon resistors in our designs, however, our German colleagues wanted to use many different kinds of devices that did not impress the American members of the team. We, finally, accepted their carbon resistors. We sent them "dura-mica" capacitors to replace their wax-coated ceramic capacitors. A few CKR-05 and CKR-06 devices were also sent to replace some ceramics in non-RF applications, however, we simply argued over the European BC-series transistors. We had no idea whether these parts were reliable or whether they had any pedigree at all. So, dozens, if not hundreds of these transistors were used in AO-7 among the German circuitry. The battlefield, however, was large polarized, filter capacitors. The Germans wished to use Aluminum electrolytic polarized capacitors. These had a tendency to change in value of capacitance over lifetime and temperature and had higher current leakage than we would have liked. However, they do have a very low mass and volume given their capacitance value. So, for the Germans, the argument for using them was mass efficiency or total capacitance for the available volume. On the other hand, the American

team wished to use Tantalum capacitors. These had low leakage (high series resistance) and had a stable capacitance value over their lifetime, and we could purchase them as high reliability devices without extensive wait times. The American modules used Sprague 350 series Tantalum electrolytic capacitors. The debate raged on during the fabrication period of AO-7. Ultimately there was one system where reliability was considered critically important - the BCR. This unit was fully redundant; however, the redundancy was selected by command. There was no auto-switch over functionality. In these units there were two 100 pF electrolytic capacitors in parallel at the 14V output. But, there were two redundant units. The Germans and Americans reached a compromise. The "A" side BCR used Aluminum electrolytic parts and the "B" side used screened Tantalum electrolytic parts offered to us from the parts cabinets at Jet Propulsion Laboratory. These were flight spares, nodoubt, from one of the Mariner spacecraft. Those details are lost to time. It our minds, for this application, where a single piece part failure could mean a mission failure, we wanted to have the best chance we could have to survive! As long as the battery survived we had hours-to-days to swap BCR units by command, even if one of these critical capacitors failed short. However, 100 pF electrolytic capacitors, if they fail short can cause energetic disassembly of other devices in the vicinity of the failed part. They really do go BANG! That issue we couldn't address and we hoped for the best. While it can be stated, at this point, we never experienced such an explosive failure on AO-7; you'll have to read Section 8 of this paper to learn the outcome of this particular "experiment" between Aluminum and Tantalum. The summary of the debates regarding small bits and pieces of our spacecraft: This is where most of the arguments took place. We often struggled with far more significant design issues. But, these we, largely made methodically and with a team spirit. Collectively, we believe it worked out quite all right in the end.

3.4 Lifetime Expectations

What can be said, from the purely human perspective, when one puts a lot of work into something (such as building a satellite; consuming four years) and the team really, really wants it to work, there is little doubt, that the desires for success place a bias on what is said outside the project. We believed that our spacecraft had a good chance of lasting for 5 years if the battery would last that long. Some of us already had a bad feeling about the quality of the NiCd battery based on the extensive testing we'd done on AO-7.

The analyses, on the one hand, and the NASA and DoD experts (those willing to render their opinion), on the other hand, were coming up with 3-year estimates. There were those NASA engineers, who knew of our project, and who didn't like 1500 km orbits and/or they disliked CMOS even more. They were coming up with 1-year-or-less lifetime estimates. This author can say, I always hoped that the lifetime of any satellite we designed and worked on would survive at least as long as it took to design, build and test it. Any longer lifetime than that, would give the team a positive return on its "time investment." So, my bet, based on that criterion, was for a lifetime of at least 4 years!

4.0 Testing and Preparing for Launch

And, test this spacecraft we did! We wanted to test it, NASA wanted us to test it and NOAA wanted us to test it even more! AMSAT had failed the first proto-flight vibration test on AO-6. The lesson learned there was fresh and strong in 1973, when we were just designing the structure for AO-7. We did, in fact, build a prototype model of this spacecraft. We made it as representative as we could, and we vibration tested it to qualification levels. All of it worked fine. In the end the test model, prototype, spacecraft wasn't identical to the flight unit, however, it was representative. Perhaps, most importantly, it gave us confidence that we knew what we were doing. None of us were mechanical engineers. In this phase of AMSAT's development, a lot of important learning was going on by this growing team of small satellite engineers. The test program was doing a lot of this teaching. We were getting lots of positive feedback. Things seemed to be fitting together. We were actually becoming real spacecraft engineers. And, there was very likely no better place to learn these important details and lessons than Bldg. 7 at NASA/GSFC. Many subsystem tests were performed by the individual experiment builders and more than a few home ovens and refrigerators gave our team the confidence they needed so that, when "*the real thins*" went together, it was going to work in a "serious" thermal vacuum chamber. Prior to the flight test program, the transponders were put into vacuum bell jars to check the high-power amplifier performance under hard vacuum. This author worked in a laboratory in Bldg. 7 that was well outfitted for these tests. We found some difficulties with the UHF/VHF transponder, which did experience corona discharge over a pressure range of from 10E-3 to 10E-5 Torr. This couldn't be corrected. This situation did not cause a failure of the experiment; however, the corona simply "ate" the RF power output of the transponder HPA and, we knew little would be left over to reach the

ground. This condition wasn't too serious, however, as we knew the spacecraft would outgas to pressures well below $10E-5$ Torr within 24 hours of launch. At these pressures the corona could no longer sustain itself. So, the precaution taken to remedy this problem was to wait for a few days before turning that experiment ON, once in orbit. The VHF/HF transponder, however, passed the same test. Corona was never a problem for AO-7 after launch.

4.1 Environmental Test Program

We had lots of help from NASA and NOAA. Both agencies wanted to be sure we wouldn't cause damage to ITOS-G, the primary satellite. We had little difficulty organizing test facilities in Bldg. 7 in order to do our environmental tests. It is worth explaining the government's concern in this instance. Secondary payloads were now, for the first time, winning this little battle to get launched on a regular basis *with bis expensive satellites*. Perhaps just one example needs to be disclosed to make the point. It is this situation that made the ITOS project manager so nervous! In 1970, the AO-5 satellite rode in the engine compartment of the Delta-2310 second stage. It was perhaps 3.5-4.0 meters removed from the primary satellite TIROS-M. In 1972, the AO-6 secondary payload was moved up to a site about 30 cm away from ITOS-D. And there was a barrier (a significant AL plate) placed between the two spacecraft, in part, to protect ITOS-D from any possible contamination from AO-6. For the launch of Delta-104 in 1974, the AO-7 secondary payload was mounted so that it was only about 5 cm away from one of ITOS-G's primary solar arrays (see Figure 13). And, once the Remove-Before-Flight covers were taken away from both spacecraft there was still very little distance (approximately 10 cm) between the two spacecraft.

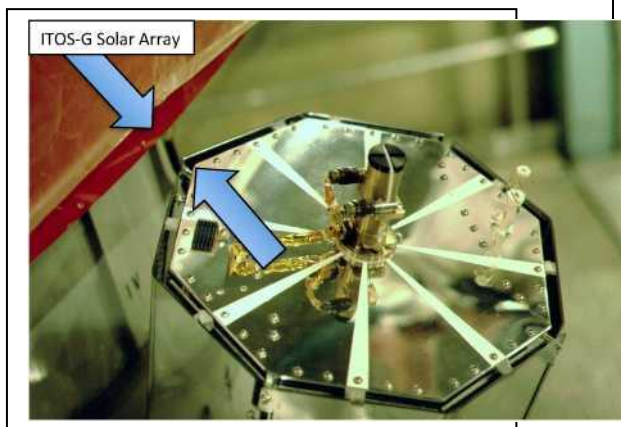

Figure 13: AO-7 and ITOS-G Proximity on Delta-

104; Remove-Before-Flight Covers were On.

To make matters more critical, the ITOS spacecraft contained a pair of radiation coolers located near the bottom of the satellites and, in fact, not far at all from the main body of AO-7. Now, radiation coolers are coated on their front surface with materials that cause the surface to get very cold - about 77K cold to be more precise. Any contaminant that attaches itself to the front surface of these coolers will not be coming off any time soon. And, any contaminant on the cooler front surface will make the cooler get warmer. If the coolers didn't stay cold, the IR Cameras on ITOS would fail to work properly. So, the mission would be over if the coolers stopped working. It is not too surprising why NOAA wanted AMSAT-OSCAR-7 to be CLEAN. They did not want outgassing products on their radiation coolers from our cheap little satellite. So, not only were we able to have a Thermal Vacuum Test once, we got to have one *twice*. The second test was, from NOAA's and NASA's standpoint, a "bake-out" test - to drive off all contaminants from the spacecraft; just before it was shipped to the launch site. But, for the author, it was more time to do lots and lots of functional tests, while we were in the space-like environment. It was the time of a lifetime for AO-7 Experimenters! Table 2 is a summary of the Environmental Test Program for AO-7.. Never have there been more willing supplicants to environmental tests.

Test Number:	Environmental Test:	Conditions:
1	TVAC Test #1	3 Cold; 4 Hot; 7 Days
2	Solar Simulation	4 Days; Turn S/C in Azimuth Manually (Sun in X-Y Plane)
3	Vibration Test	To Proto-Flight (S-320-G1)
4	Separation Test	Clamp-band Deployment; Live Pyros
5	EMI/EMC Test	MIL-STD-461; RE-02; Self Compatibility
6	Thermal Coatings Installed	GSFC Thermal Branch Support
7	TVAC Test #2	2 Cold; 1 Hot; 10 Day Dwell HOT

Table 2: AO-7 Environmental Test Program (In Order of Test Performed)

The tests were fascinating, especially the 2nd time around, and we really *did* know what we were doing by then. Two events were worthy of note

coming from all of this testing. The first had to do with contamination during TVAC Test #1. AMSAT had “learned the ropes” on clean materials. You might call it the crash course, however, while I was at work at NASA, I was surrounded; in an environment that was teaching me about clean adhesives and paints and plastic products, including wire coatings at an amazing rate. The author had a minor in chemistry as an undergraduate and noting could make me happier than learning the details regarding low outgassing materials. So, noting in our spacecraft outgassed or had a high CVCM or TML. However, when we placed AO-7 in the chamber we placed it on a mechanical payload attach fitting that we had borrowed from colleagues at the Delta program. Unknown to the author, there was a cable connected to a strain gauge, which was used to tighten the Marmon clamp band around the satellite. This was not strictly needed and the cable could have been removed. The Delta people hadn’t told us that the rubber covering on that cable was made from a high-outgassing material. And, we had assumed that nothing that would fly on Delta would be high outgassing in nature. What we did not know is, this cable, once the Marmon Band had been secured and the strain gauge had lived it’s useful life, the cable was routinely cut-off, by a MDAC technician. The strain gauge remained and the cable was removed. The result was, we left this small piece of cable within the TVAC chamber during the first TVAC test. We used witness mirrors to test for contaminants, and to make a long story short, when we saw the chemistry report from the witness mirrors we were in shock! The cable had ruined the outgassing aspects of TVAC Test #1. The outgassing components on the mirrors were too high and the contaminants were bad, chemically. The spacecraft needed a few small circuit corrections based on results from our own measurements, however, from NOAA’s standpoint we had failed the test. We had made a mess of the outgassing performance. What helped our case was, AMSAT had found the problem by ourselves and we quickly went about proving that the strain gauge cable was the outgassing source. We knew immediately this cable was the only possibility of being the source. There was no damage from the contaminants that had escaped; certainly not to AO-7. But, this put a lot of pressure on TVAC Test #2. And, it stretched our credibility with NASA/NOAA just a little bit more.

The second issue that came up occurred during the EMI/EMC Test. The spacecraft was taken into a proper Anechoic Screen room for this particular test. This test was not done, in this instance, at NASA/GSFC. During the testing, the spurious radiation from the spacecraft that we observed

during the RE-02 test (these day’s it is RE-102 in MIL-STD-461,2) was quite within expected limits. However, we noted in our own self-compatibility test that during testing of the UHF/VHF transponder, that the 3rd harmonic of the transmitter was desensitizing the UHF Command Receiver. This was the first time the spacecraft had been in a space-like RF environment with all of the antennas connected and deployed. And, the problem showed up in this test for the first time. We took this very seriously and we made some considerable improvements. However, there was not sufficient time or money to re-perform this test, after corrections were made. We ended up flying the spacecraft with this known potential deficiency not tested and once in orbit, we realized our “fixes” were inadequate. AO-7 has one very deaf UHF command receiver. AMSAT still suffers with the-blessings-and- the-curses of harmonically related satellite bands. The advantages made our design of a common VHF/UHF Combiner/Antenna possible. However, this particular coin sure had two sides. For the whole 50-year life of AO-7 we have lived with one command receiver - and that one still works. There can be no excuse for not testing adequately! The laws of physics don’t care about a lack of funding.

TVAC Test #2 was very successful. We had virtually no outgassing from the spacecraft and the offending cable was now long gone. We had two weeks of extra time to functionally test AO-7 while it was being cooked to remove ANYTHING that would come off. We did not contaminate NOAA-4’s radiation coolers. The two-week bake-out test was conclusive in NASA/NOAA minds and we got two extra weeks of functional testing in a space-like environment.

4.2 Functional Testing of AO-7

You’ve heard it at the SmallSat Conference every year and you will hear it again this year. The best way to assure the reliability of any small satellite is test, test, and test. We hope this paper will once again reinforce this behavior. No spacecraft this author has ever worked on was able to be functionally tested like AO-7. The additional environmental tests, imposed by NASA, gave us the time we needed and we used it for more functional testing. We established a ground rule for our Experimenters based on our experiences with AO-6 and AO-7. The rule was we wanted every single component (module) in every satellite, into the future, to experience at least 1000 hours of “burn-in” time before launch. The time could be accumulated at ambient conditions and/or during environmental testing such as TVAC. The notion

was quite simple. If a module wasn't needed at a particular time, and it would be just sitting on the shelf, it should be *under test* sitting on the shelf. However, our rule was, this should amount to 1000 hours and a log was required from each Experimenter to demonstrate that this milestone had been accomplished. Large, professional spacecraft, at that time, only require about 100 hours of similar testing before launch. Even now, we believe this is a good SmallSat rule to follow. We also believe this testing offsets some aspects of using COTS piece parts instead of Qualified Devices.

4.3 Let's Launch It

By then end of September of 1974, AO-7 was ready for transport to the Western Test Range (WTR). We kept doing functional tests, all the time - even when we got to WTR. The initial part of the launch campaign went smoothly. We completed our final "long-form" functional testing. We had an excellent opportunity at the launch site to meet, once again, with the Spanish INTASAT team and we were then able to exchange many stories regarding our common SmallSat experiences. The two secondary spacecraft were mated on 10 October 1974 and the fairing was installed a few days later. Figure 14 shows three members of the AMSAT team at Delta SLC-2W after the mating. These were indeed happy times. The author went back to Washington, D.C. to set up a ground station and to await the launch.



Figure 14: Level 5; SLC-2W; Happy Days!

Fate was not though with us yet. At the Flight Readiness Review (held for Delta at T-3) the NASA Review Committee found that they were not happy with a failure that had occurred on the assembly line for the DIGS (Delta Inertial Guidance System). A critical connector on one

DIGS "box" had several pins that were found to be OPEN CIRCUIT. These findings, the repair of the offending connectors, and the retests, as described by the vehicle contractor McDonnell-Douglas, were not deemed to be satisfactory by the Review Committee. Consequently, NASA grounded DIGS and required the contractor to replace all connectors associated with DIGS on the entire flight assembly line. That also meant the DIGS box on *our* launch vehicle had to be removed, the main connector replaced and then the box had to be re-tested. Then DIGS had to be put back on Delta-104. This exercise added exactly one month extra to the launch schedule. A few days into this month, the NASA Design Review Committee decided, without advising AMS AT, that the Marmon clamp bands would have to be removed from both INTASAT and AO-7 because, these clamp bands were being "subjected to" a "salt air environment." (SLC-2W is on the ocean beach about 300 meters from the Pacific Ocean). The Committee believed that stress corrosion could occur to the metal materials of the clamp band, if they were exposed to this environment for a "whole" 30 extra" days. (What! The 5* Level of SLC-2W, where the satellites were, was air- conditioned). The two satellites were removed from the vehicle, without summoning the AMSAT team to go back to WTR. This was dangerous to AO-7 because it had 4 live pyros, set to be fired, 4 seconds after spacecraft separation. They were to deploy the 10meter dipole antenna. Had the MDAC technicians not remembered to remove the SAFE/ARM plug from the spacecraft before de-mating, the 5* level on the gantry at SLC-2W would have been filled with copper antenna material very shortly after the de-mate would have occurred. The technicians didn't forget. The spacecraft was safe, and this author was decidedly not a happy camper. My complaint to the Technical Project Manager of Delta - then Charlie Gunn, was given a brief response. I think he'd rehearsed it. "You didn't provide us with a De-mating Procedure 30 days prior to launch (as required). We had no choice but, to remove your payload ourselves." At this point in my career, I didn't even know what a de-mating procedure was. But, I suppose, life is for learning.

A few weeks later, our team returned to WTR (this time at our own personal expense) - AMSAT was running out of cash. We re-mated our spacecraft. INTASAT had already re-mated. And, MDAC put the fairing back on the vehicle - now, for the last

time. We said our goodbyes to AO-7 one last time.

Delta-104 was launched on 15 November 1974 into a 1460 km, circular sun-synchronous orbit. This took place with no anomalies. The critical parameter for this orbit was the inclination of 101.73°. DIGS worked fine. The inclination error at injection was 0.05°! If the reader would like to learn more about the orbit of AO-7 over 50 years, and there are some surprises, please read our paper regarding this satellite's orbit perturbations (SSC24-S1-04), in these proceedings.

5.0 AO-7, The Sleeping Beauty SmallSat

AMSAT-OSCAR-7 has had an unusual history compared to any other satellite we are aware of. Goodness knows, by now, there have been many small satellites. We've described the unusual "second failure" of the NiCd battery we'd obtained from NASA. Figure 15, summarizes AO-7's history to date.

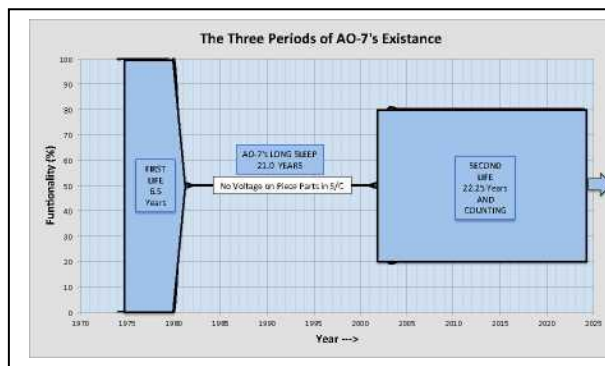

Figure 15: The Three Periods of AO-7's Existence

5.1 AO-7 Primary Mission (FIRST LIFE)

AO-7 lived a very healthy lifetime of 6.5 years. Not to over-state the case, however, AO-7 during its primary lifetime, outlived both co-passengers launched by Delta-104. The ITOS spacecraft from the TIROS-M series of spacecraft were limited in their lifetime, primarily by the aforementioned radiation coolers required by the IR camera systems. As these were operational instruments they had to be replaced immediately when the redundant (last remaining) unit showed signs of deterioration. These replacement missions back then, were called "Call-Ups." The radiation coolers, as noted above, are sensitive to contamination over time. It is also true that the front surface coatings degrade with radiation of all types. This tends to increase the radiation cooler temperature, making

the "cold reference" they provide, less cold. With time the IR cameras, become unusable due to elevated temperature. The technology used yielded a spacecraft lifetime of about 5 years for an ITOS of that generation. INTASAT had a 2-year timer and no command receiver. The timer worked. All of the spacecraft achieved their mission objectives.

For AO-7's part, the results of several of the Experiments, beginning with the two Transponders are summarized next.

5.1.1 AO-7 & The Amateur Satellite Service

It is significant that the three AMSAT satellites AO-6, AO-7 and AO-8 had long, overlapping lifetimes. The first two were in ITOS SSOs, while AO-8 was in a lower Landsat-type SSO (circa 800 km). These overlapping conditions resulted in continuity of service, which made the Amateur Satellite Service a real and viable service. Tens of thousands or licensed radio amateurs used these satellites, many on a regular basis. These three LEO satellites weren't quite a constellation, however, there was a definite pattern of passes that allowed users to be able to count on the spacecraft "being there" for communications. Those who know a bit about the hobby of amateur radio know that these folks love to set goals for themselves. Examples include, longest communications, largest number of regions of the Earth contacted, most countries contacted, most U.S. States contacted, lowest power used to make a communications and so on. The list is virtually endless. Awards are issued to those achieving the best results in each category. All of this continues to occur, but now, also via satellite. In this category, two are particularly noteworthy:

a) *Longest Communications:* During the lifetime of AO-7, two stations using the Mode A (VHF-to-HF) transponder completed the longest two-way LEO communications. One station was in Columbia, MD and the 2nd station was on Oahu in Hawaii. The reported GSD (ground surface distance) for this communications was 7900 km. The elevation angle involves on both sides of the link was 0 deg. What may have given some assistance in this case; the downlink on 29.5 MHz is in the HF frequency region of the spectrum and these two stations may have gotten a small boost from the ionosphere due to a bit of diffraction. The geometry is depicted in Figure 16.

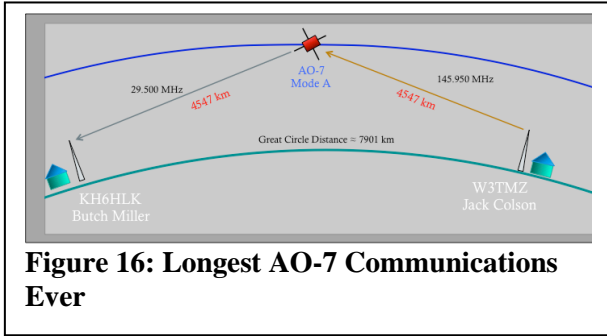

Figure 16: Longest AO-7 Communications Ever

b). First Earth-Space-Space-Earth Communications Relay Demonstration Ever: The downlink spectrum of AO-7's UHF/VHF transponder overlaps with AO-6's VHF-to-HF transponder. The overlap of the two is approximately 50 kHz wide. The two orbits are the same - almost. AO-7's mean motion (reminder: one of the TLEs) is slightly higher than that of AO-6. Which means, once every year or so, AO-6 will "lap" its younger brother in space. During the time when the two spacecraft are in closer proximity, it was already known to be theoretically possible (if AO-7 has its UHF/VHF transponder on) for one user to communicate through two spacecraft in succession, with the downlink of AO-7's transponder being relayed through AO-6's VHF/HF transponder uplink, and then, with the doubly relayed signal arriving on 29.5 MHz to another user on the ground. This could be done, in certain geometries, in both directions, making a two-way double-hop communications possible. The first successful Earth-Space-Space-Earth relay of this type took place on January 6, 1975, early in AO-7's lifetime and during the first occasion when AO-6 approached AO-7, in their very similar orbits. The two stations were both located in the state of Texas. Figure 17 shows the relay characteristics.

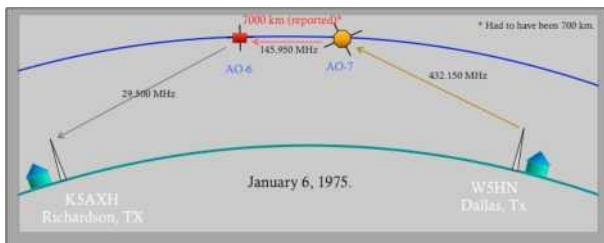

Figure 17: First Earth-Space-Space-Earth Communication Ever. Made via AO-7 and AO-6.

This method of communications was also conducted and reported by 55 user stations from 12 countries during 1975. These events were documented in the IEEE Proceedings in October of 1975. ⁴

5.12 The Use of CodeStore

While CodeStore was used on both AO-6 and AO-7 to demonstrate non-real-time communications via satellite, it was never used by independent remotely located stations in order to demonstrate two-way communications in that way. The memory facilities required on-board and the lack of any firmware that even approached the capabilities of a file handling system did not exist in 1972-74. That would have to wait for another day, where once again, four AMSAT spacecraft, in a small constellation, would demonstrate a proper store-and-forward packet handling system. That was to occur in 1990.

CodeStore went into service as a broadcast device allowing users to receive, in Morse Code, the latest, (then) NORAD TLEs. CodeStore was a complete success, however, it was largely taken for granted, over time. It saved command stations a tremendous amount of work, avoiding the need for a global network of operators, who would otherwise be needed to relay the same data. It would be far from the first or the last digital device to be taken for granted.

5.2 AO-7 - Support to Space Education

In Section 3.2.5 it was explained how using a Morse Code telemetry system could help to enable a novel

Satellite Educational Program. By 1975, Morse Code telemetry was being downlinked in abundance from two spacecraft, both available during class-time and the spacecraft educational program went into full swing. From the early 1970's through to the late 1990's many Revisions of *The Satellite Experimenters Handbook* ⁵ were published by the ARRL. In 1996 this document was largely replaced by a broader publication, to be known as *The Radio Amateur's Satellite Handbook*.

⁶ This documentation became the first source for teachers who wanted to introduce a spacecraft technology section into science curricula. Dr. Martin Davidoff, K2UBC, was the author of both of these useful and practical texts. Many hundreds of classrooms, in several countries participated in this program. The United Kingdom and Germany both implemented their own independent versions of this program. The AMSAT Satellite Educational Program has now largely been merged with the *ARISS* (Amateur Radio via the International Space Station) program. It is understandable why students would want to talk to an Astronaut rather than take telemetry data, as a means of being introduced to spacecraft and space science. Radio amateurs still provide the ground station equipment and the educational environment in which the newer

ARISS program is carried out.

5.3 COSPAS/SARSAT Experiments

There were not very many joint US/USSR space programs back in the late 1970s, however COSPAS (Russian)/ SARSAT (Search and Rescue Satellite) was one of them. As envisioned by spacecraft engineers from both countries, the concept was to relay signals from beacon devices already installed on large and small aircraft (ELTs) and on ships and smaller vessels (EPIRBs). These one-way beacon transmitters, originally intended to be received by surface rescue parties, could also be received and transponded by a LEO spacecraft, greatly extending the rescue potential. The signals could also be Doppler tracked, one-way, by processing the beacon uplink signal on-board the spacecraft. This would allow the spacecraft to find the source beacon's location immediately. This would allow the emergency beacon to be identified and located and the position stored for immediate downlink at the next available ground station. [NOTE: We know it is hard to remember but this era was just before GPS], This concept, immediately before cooperation with the Russians occurred, had been the idea of Dr. Dan Brandel of the Communications & Navigation Division at NASA/GSFC. The transmit frequencies were already established by the existing population of ELT and EPIRB beacon devices already distributed worldwide. The relevant frequencies were 121.5 MHz (civil beacons), 243.0 MHz (military only) and 406.0 MHz (civil; newer technology). There was a need to test and demonstrate the feasibility of this concept. The eventual home for such COSPAS/SARSAT transponders would be as operational payloads on NOAA/ITOS polar spacecraft as well as on Soviet equivalent spacecraft (COSPAS). NASA no longer had available spacecraft in LEO orbit with any form of VHF transponder or equivalent payload. AMSAT did. After considerable discussion and some detailed Doppler analysis, AMSAT and NASA, made arrangements for Dr. Brandel's group to conduct a series of measurements of transponded signals (simulating ELTs) via the VHF/HF transponder on the AO-6 and AO-7 spacecraft. The difference here; while Brandel expected to track the one-way uplink Doppler on-board, the experiments conducted were two-way and so included both the uplink and downlink Doppler. The HF downlink added an error source to the measured Doppler since the ionosphere can add a range error.

The tests were highly successful and it was possible to get good estimates of the uplink transmitter's original location, despite the measurement error in subtracting out the Downlink Doppler value. The

COSPAS/SARSAT program went ahead at NASA/GSFC and at Roscosmos in the USSR. This program has been operational since 1982. From that time until 2021, when the program merged with others providing similar capability via LEO, MEO and GEO spacecraft, the program had saved the lives of 57,413 persons in 17,663 separate rescue events, involving downed aircraft and ships at sea.^{7a 7b} AMSAT is proud to have been a key organization helping to validate the technology for the COSPAS/SARSAT program. We think most would agree this was a useful contribution made by small satellites to help others in a time of need.



Figure 18: COSPAS/SARSAT Program Logo

Radio amateurs using AO-6 and AO-7 during the 6.5 years of AO-7's primary lifetime carried out many other experiments. For a short while radio amateurs who work at the National Institutes of Health (NIH) conducted some data transfers from ambulances, to hospitals, via the AO-7 spacecraft to demonstrate that EKG data could be transferred in this manner. These were successful; however, such demonstrations might not be considered particularly practical. Members of the amateur radio community working with other civil authorities conducted other emergency communications demonstrations. The ARRL sponsors an event each year known as "Field Day". Over this weekend in summer every year, amateurs use portable equipment to demonstrate communications that could be carried out under emergency conditions. This takes the form of a contest (who can do the most communicating in 48 hours) and there are bonus points for using emergency power sources and special means of communications. As early as 1972 AO-6 and then AO-7 were included in the modes of communications that *field day* operators could use. And, they would get bonus points for doing so.

6.0 AO-7 In The “Sleeping Beauty” Phase

In late 1980, AO-7's poor, abused, NiCd battery began to show serious signs of increased series resistance. This was a sure sign to AMSAT command stations that the end was in sight. Watching one's spacecraft die like this is a lot like observing a terminal patient departing. In our case, when the cells began to fail in about May of 1981, they failed one after the other and in pretty rapid succession. The cells had been originally “matched” for capacity by NASA. And, indeed the cells all failed within a matter of weeks of one another. We were able to witness, via telemetry, about 3 cells failing as the battery jumped abruptly downward by about 1.2 V for each cell failure. The cells failed SHORT, as we already knew they would. We once had the telemetry plot of the battery voltage from this period; however, this author wasn't able to locate this data for presentation here. Suffice it to say that we witnessed the reduction in battery voltage via the M.C. TLM system. By the time the fourth cell was about to go, some of the voltage regulation had been lost. When the 4th cell failed we could no longer find the spacecraft. AO-7 was gone - and we thought for good.

AO-7 stayed asleep for 21 years, to the nearest month.

From AMSAT's perspective, it was a good thing that AO-7 quit. The end of its lifetime, foretold, in some ways, the dawn of the next phase of AMSAT's work. Some years earlier we had realized, the future of a proper radio SERVICE (in our case the Amateur Radio Satellite Service) must occur at higher altitude. This would enable long range, communications via satellite.

AMSAT called the early OSCAR satellites, Phase 1 of the ARSS program. Phase 2 of the program consisted of the long-lived LEO SSO communications satellites, of which AO-7 had been the elite example. Phase 3 of the program was to be satellites in HEO orbit. These orbits we were planning had the same properties as the Russian Molniya orbits.⁸ Now, these spacecraft needed considerable AV to get to their final orbit. And that meant - ROCKET MOTORS - on a SmallSat! We were excited. As early as 1978, we'd begun our next adventure. AO-7 was already moving into our imagined history. We were fully into Phase 3 of our adventure. Thank goodness the older satellites were exiting the scene so we could get on with the creation of the future!

During the time of AO-7's beauty sleep, the USU/AIAA Small Satellite Conference was born.

7.0 The Second Lifetime of AO-7

Then one day, after AMSAT had already attempted to put three Phase 3 satellites into orbit (two successes and one L/V failure), AO-7 woke up again. This was only possible if something caused an open circuit in the battery. The 10-shortened NiCd cells represent a dead short across the output of the BCR. And, that meant the solar arrays were dumping any power they might produce, through the BCR, to the battery itself - and straight to ground. No aerospace engineers the author has ever found can explain a shorted NiCd going open again! The root cause of this 2nd failure is still “open to question”. Why? How? Help!

A very active user of AO-7, Pat Gowain (G3IOR) from the UK, made a telephone call to Perry Klein (first AMSAT President and designer of the VHF/HF repeater (transponder)). This was on June 21, 2002. Pat wondered if we had launched a new LEO spacecraft or something? He wondered if it was a new experiment or perhaps a balloon payload over France, launched by radio amateurs there? He was hearing Morse Code Telemetry again on 145.980 MHz. This had been the old beacon frequency of AO-7. He played Perry a tape recording. It sure sounded like AO-7 telemetry. Even some of the values in the telemetry stream still made sense.

Many radio amateurs who were satellite enthusiasts very quickly began to observe the signals from AO-7. The satellite was found in Mode-A, transmitting on 29.50 MHz as well as Mode B, transmitting on 145.98 MHz. However, it became apparent right away that, when the satellite was in eclipse, it was not heard. The battery was now OPEN CIRCUIT. And, when it was heard, it was no longer in the mode of operation it would have been in - during its first lifetime. So, the Experiment Control Logic (ECL) wasn't doing what it was supposed to. It took a week or two to bring clarity to what was being observed. The spacecraft was showing up regularly, however, much seemed random in nature.

7.1 What Still Works and What Doesn't?

The author was THE individual who actually fabricated the flight ECL module. So, I was the logical individual to begin poking into what was happening. What I deduced was the spacecraft must be following a sequence of events based on the orbit and particularly based on the eclipse cycle. We now know that at the time of its re-discovery AO-7's orbit had drifted (precessed) to an LTDN value very nearly where it had started back in 1974.

That means the orbit was nearly 8 AM at the time of its descending node (8 PM at the ascending node). This orbit yields nearly the maximum eclipse duration possible for a spacecraft in these particular orbital conditions. When AO-7 is in eclipse now, it is OFF. There is no power arriving at the input to the BCR from the solar arrays. When the sun rises at AO-7, the voltage comes up quickly on the solar arrays. It will take only a few seconds for the voltage on the arrays to reach 6.4 volts from zero. This input voltage is converted to 13-14 volts by the BCR. This higher voltage is delivered to all of the satellite loads and the to the battery. But, the battery is OPEN CIRCUIT; it does not exist, so far as AO-7's circuitry is concerned. This soaring voltage will very quickly power the Instrumentation Switching Regulator, which powers ALL of the CMOS circuitry in the spacecraft. This includes the Command Decoders (2 redundant) and the ECL. These three modules are now the critical players. It is possible as the 10V arrives at the Command Decoders, they may come up with the decoder outputs in a random state. There may be pulses produced on any or all of the command discrete lines (of which there are 70, between the two decoders). The ECL, as it receives 10 volts will likely come up in a random mode, AND, in addition, it may be receiving different pulses from the Command Decoders, since many of the discrete command lines terminate in the ECL. The combination of these sets of actions means that the outputs of the ECL will come up randomly with the AO-7 sunrise. This randomness applies to all commands that could be delivered by the command decoders. This includes the mode settings (which transponders and beacon options come on) and other actions possible within the logic functionality within the ECL. By example, that includes which telemetry encoder is connected to which beacon. Through observation over time, we have determined:

a) When the satellite orbit keeps the spacecraft in 100% sun, the ECL logic functions normally, except that the battery under-voltage detection circuitry no longer has a battery to work with. The inputs are essentially, shorted to ground. Key to note: the 24-hour timer still cycles everything normally. In this scenario, the two transponders cycle A-B-A-B... just as they should, every 24 hours.

b) When the satellite orbit has an LTAN sun angle such that the orbit goes into eclipse, the ECL and the Command Decoders (in combination) produce a random set of outputs, as the spacecraft exits eclipse. This puts the spacecraft in a random set of modes, EXCEPT; we have now observed that this probabilistic process - strongly favors Mode B

operation. And, that is a good thing. This allows more users to access the best available communications device.

Within three weeks of the re-emergence of AO-7, we had reconfigured a command station, complete with a software version of the audio generation technology. The original ground station Command Encoder hardware, long-gone, had used discrete hardware to generate the command tone sequence, as disclosed in Section 3.2.8. The Command Stations themselves were also long gone. Phase 2 of AMSAT's program was completed and Phase 3 was well underway. On July 11, 2002, almost 21 years to the day, from AO-7's final battery cell failure, AO-7 successfully received its next command. AMSAT member Mike Seguin, N1JEZ, using a specialized audio software system to generate the tone sequential commands and using a 145 MHz transmitter to uplink these commands to the spacecraft, accomplished this feat. This first command simply changed the Morse Code rate of the M.C. TLM system from 10 WPM to 20 WPM and back again. This had always been our standard test command pair. Of the 35 commands available to be sent we believed 7 of them should be omitted. These involved switching the BCR (discussed above) and the operation of the 2304 MHz beacon. This left 29 total commands to be verified. Over the course of the next few weeks Mike was able to verify 100% of this subset of 29 commands successfully with Command Decoder A. When he attempted to use Command Decoder B, he was not successful in getting the spacecraft to accept or respond to those commands. Thus, the initial conclusion (and one that still stands) is, we assume Command Decoder B may have failed. There is the possibility that the command enable tone was incorrect or that some analog circuitry along the pathway to the "B" unit had failed. Further investigation was not carried out, since we had one working decoder and there were other investigations necessary.

During this set of commanding sessions we verified that the following elements of the spacecraft were working (recall, at this epoch the spacecraft had been in orbit for 28 years and for 21 of those years the spacecraft had had its power bus shorted to ground). The solar arrays would not have delivered power to the loads, due to the short circuit.

a) The UHF/VHF Transponder is fully functional. It works in both Mode B and C. It has a very sensitive receiver as it always has had. It appears the gain of the transponder has increased. We sometimes see two spurs in the passband of the downlink that suggest the gain may be high enough

to generate an occasional, small, instability. As there is no battery and the HPA of this transponder has a high PAPR (See Section 3.2.2) on power peaks there is evidence of distortion from “saturation” of the HPA. This occurs when all of the uplinking user signals demand more power than can be generated by the solar arrays. This is more common now, as there is less array power and nothing but a few electrolytic capacitors, which can provide any power buffering. The battery used to provide the peak power demands of this transponder. Multiple users can share the transponder if they use a low EIRP on the uplink. 10 watts of EIRP is likely all that is required. Frank and Scott Wiessenmeyer, the two co-authors of this paper have verified that peak S/N values for SSB and CW stations are routinely above 10 dB (peak) and at high elevation angles the S/N can be on the order of 20 dB PEP. CW (Morse Code) signals achieving 15 dB S/N are not uncommon. This transponder is uplink- limited, in the sense that the transponded noise floor can be observed on the downlink channel. When the orbit has eclipses, and if the system is not actively commanded on all passes (which is true the vast majority of the time), the spacecraft favors Mode B (UHF/VHF transponder) ON. This transponder’s hardware does not show significant signs of radiation damage. Some “chirp” (short term frequency change) is commonly observed on transponded carriers or CW signals. This occurs because the uplink users are literally “pumping” the voltage of the bus by keying their uplink transmitter. This becomes worse

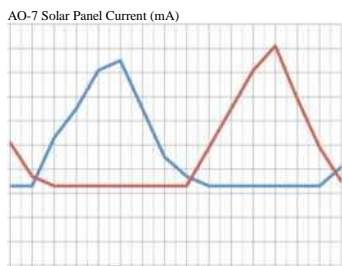

with heavy loading. This is one of the most obvious outcomes of not having a spacecraft battery.

b) The VHF/HF Transponder is fully functional when it is ON. When the orbit has NO eclipses, the 24-hour timer switches between Mode A and Mode B every day, as it always did when the battery was functional. At these times, many users enjoy Mode A. Signals are, on average perhaps 5 dB weaker than in Mode B. However, since these times of operation have been fewer in recent years (more on this later) Mode A is not as popular as it once was. The hardware, however, seems not to have been degraded by radiation.

c) The 435.1 MHz Beacon Transmitter is working very well. It still indicates a power output of 350 mW from TLM. The beacon works in both FSK & CW telemetry modes. The FSK frequency shift, which should be 850 Hz is still spot on. S/Ns for this beacon can be as high as 20 dB. When it is enabled, and this situation occurs randomly AND during times when there is no eclipse, large quantities of RTTY telemetry can be gathered. Examples of this performance will be demonstrated during the conference session for this purpose. This beacon responds to all of its commands. This beacon does not exhibit frequency chirping, as it transmits constant envelope and does not generally task the solar power budget very significantly.

d) The M.C. Telemetry Encoder is still the little workhorse it has always been. The Morse-Code speed commands, which switch between 10 and 20 WPM work fine. The telemetry format, as you can see and hear for yourself during the demonstrations, is solid and with no errors. The channel sequences are correct and it appears that the A/D converter is still within calibration. This is a major point. It could be anticipated that analog circuitry will be biased significantly by radiation. We’ve explained the channelization scheme for this encoders MUX system in Section 3.2.5. Channel 6D, the last analog channel is a calibration channel. The A/D converter has an analog voltage range of 0.0 to 1.0 V. It is possible to scale the channel by means of operational amplifier ahead of the ADC. There is, however, no such gain associated with the calibration channel. Instead, the output of a precision reference Zener diode feeds this channel. The output impedance from the Zener diode is quite low (not subject to load changes). This source is located in the ECL, which is a module nearby the M.C. TLM Encoder. Both modules are better shielded (4-6 mm of AL equivalent). Before launch this precision reference was set to 0.5000 V. The output of channel 6D during the primary lifetime, always read 50. So, that calibration factors for this channel is $Y = mX + b$. $b = 0$ and $m = 0.01$. Today, after 50 years, the numbers being received are between 49 and 51, with 51 being the most commonly observed number this author has observed. So, both the precision reference and the ADC seem to still be calibrated. The numbers were also the same at 28 years into the mission when AO-7 was rediscovered. The changes in either the calibration of the ADC or the precision reference for the spacecraft, to first order, appears to be $< 2\%$. You may compare the two frames of M.C. telemetry shown in Fig. 4. The value for the calibration channel, 6D for both frames was “51”. The frames are separated in time by just under 50 years!

However, we must report that the analog telemetry devices are, generally, quite a mess in AO-7. There appear to be analog biases in many of the channels. Time has not allowed us to analyze all cases yet. However, Figure 19 demonstrates one fairly clear example. An important feature can be seen in this plot, as we see the +X and -X quadrant solar panels producing current over about one spin period. This data will take us back to our photon propeller experiment. This will be discussed shortly, however, lets focus here on the baseline current. When the blue +X panel is producing peak current, the -X panel should be zero current, and vice versa. However, it is clear that the telemetry is now telling us that the baseline current is no longer 0.0 mA. It now measures about 320 mA for both channels. So, there is, at least, a bias offset now in the measurement of 320 mA associated with both the +X and -X array current channel. These array current channels are at least still useful. There could be a bias in the amplitude (gain) of these curves as well. In other words, the gain of the amplifiers, which scale this current to a voltage of between 0.0 and 1.0 V, could have also changed. However, after some review we believe the currents we are seeing here, when adjusted for the 320 mA bias, are about 20% or so less than the original readings. We believe this reduction is in the correct order-of-magnitude to allow for the radiation damage to the solar arrays we might expect to see. There is more to come on this topic.

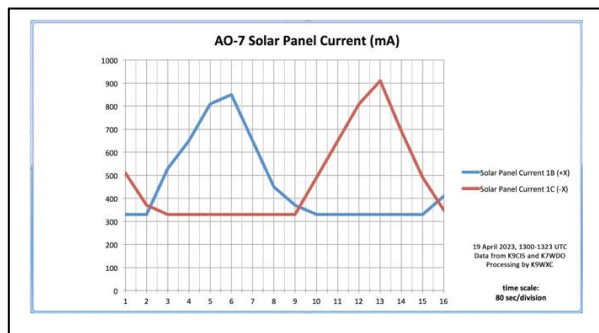

Figure 19: M.C. Telemetry of +X and -Y Solar Panel Current

Another example of apparent radiation damage to analog circuitry is associated with the thermistors used throughout the spacecraft. All are now in considerable error. Yellow Spring Instruments in Yellow Springs, Ohio, made these thermistors. Many NASA/GSFC spacecraft have used these specific devices and similar thermistors made by the same vendor. They were sold as high reliability components and AMSAT used these as screened devices. In particular, we used a linearized

thermistor: P/N: YSI-44203. We used this same thermistor everywhere in AO-7 and, for that matter, in all of our spacecraft from 1972 until 2005. This device is a network containing 1 thermistor and two 0.1% screened metal film resistors. When presented with a precision reference voltage (in our case 0.5000 V) the network produces a voltage *linearly* related to temperature over the range -30 to +50 °C. Table 3 is one, which this author can assure you, is like none you've ever seen before. There were just 7 thermistors being sampled by the M.C. TLM encoder. Those are shown here with some other telemetry samples, situated at the end of the frame. So, this table is not too large to review. Table 3 gives the temperature measurement for one representative sample taken from **Orbit 69** on 21 November 1974 (AO-7 was one week into its mission and the temperatures had reached steady state and the spacecraft had stabilized) and from **Orbit 220,206** (AO-7 was 48.099 years into its mission) and again a representative sample is show. We notice, once again that the ADC in the M.C. TLM Encoder seems to be in good calibration.

Table 3: S/C Telemetry Changes Over 48 Years

Table 3: S/C Telemetry Changes Over 421,624		21-Nov-74	Mode B	21-Dec-22	Mode
Channel No.:		Orbit: 69	Unit:	Orbit: 220,206	Unit:
3D	Battery Te m pe ratu re	18.84	°C	15.88	°C
4A	Base plate Te m pe ratu re	12.92	°C	-21.12	°C
4B	PA Temp. - 2m/10m Transponder	15.88	°C	-28.52	°C
4C	+X Array Facet Temperature	5.52	°C	-41.84	°C
4D	+Z Facet Temperature	9.96	°C	-44.8	°C
5A	PA Temperature - 70cm/2m Xpdr	29.2	°C	49.92	°C
5B	PA Emitter Current 2m/10m Xpdr	11.67	ma.	58.35	ma.
5C	Modulator Temp. -70cm/2m Xpdr	26.24	°C		°C
5D	Inst. Sw. Reg. Input Current (@ 14.3	31.5	ma.	54.46	ma.
6A	2m/10m Xpdr RF Power Output	0	W	1	W
6B	RF Power Output - 70 cm Beacon	400	mW	313.6	mW
6C	RF Power Output - 2304 MHz Beacon	0.01	W	0.04	W
6D	TLM I/2 Reference Calibration	0.50	V	0.51	V

The bias in the reference voltage is consistently +1 count or approximately 10 mV. However, the temperature values are another matter. The battery temperature, has, according to telemetry, gone down by 3 °C. However, the % sun for the orbit, at the time of the more recent measurement, is higher that it was back in late 1974, so if anything, one would expect a warmer temperature for the battery not a colder one. We note that the battery thermistor is the most radiation shielded component in the spacecraft; the thermistor bead is located down amidst the cells and the battery is located at the center of the spacecraft. We'd estimate there is more than 10 mm of equivalent shielding for that piece part. We would thus, estimate this thermistor may have seen <100 kRADs (Si) total dosage. However, if we observe the temperatures that are around the exterior of the structure, all of these are reading high negative values and are almost all out of the calibration region of the thermistor. These measurements are, undoubtedly, in error and all in the same direction. What we are unable to explain are the temperature measurements coming from the

UHF/VHF Transponder. When these measurements were made, this unit was OFF. Thus, the very high temperatures indicated are very unlikely on the high side of reality. In summary, the battery temperature measurement seems to be plausible but shows signs of a negative bias. The thermistors near the periphery of the spacecraft seem to demonstrate a very large negative temperature bias and the two thermistors within the Mode B transponder seem to have a positive temperature bias. While the author is inclined to believe the negative thermal bias condition is caused by radiation to the thermistors themselves (or their support parts; 2 RNR55 resistors), we cannot explain the opposite (+) bias on the transponder thermistors. This anomaly has not been resolved at this reporting.

We note that the power reading for the 435.1 MHz beacon seems just as it should be, given aging. It has gone down slightly over the 50-year period, since launch.

e) The *RTTY Telemetry Encoder* is still functioning as it was designed in many respects. It is consistently producing the correct formatting; including the carriage return (CR) and line feed (LF) characters required for old electro-mechanical Teletype machines to function properly. It is also inserting a “-“ character between words. This tells us that the CMOS digital logic is working largely as it was designed. There is one obvious error occurring on every frame. If one observes the encoder format, for the frame shown in Figure 4; for column 8 (which includes analog channels 08, 18, 28, 38, 48 and 58) digits 2 through 5 are represented by 0000. The analog values and the 2nd digit of the channel number are simply missing. This suggests a failure at some point, of the channel multiplexer. This is clearly a failure of some CMOS device to do its function. While it would be convenient to blame this anomaly also on radiation, if one is objective, we also cannot rule out a simple piece part failure either. Reviewing data back to the time of 2002, this anomaly seems to have been present since the beginning of the SECOND LIFE of AO-7.

The RTTY TLM Encoder has not been used very much during AO-7's SECOND LIFE, for the analysis of spacecraft engineering housekeeping. Simply put, the M.C. TLM Encoder is simpler to check. The RTTY TLM Encoder has been used to carefully inspect its data format. This unit makes use of nearly 50% of the CMOS ICs in the entire spacecraft; therefore, we believe it represents the highest logic complexity in our system. We can report that the format itself seems to be precise, notwithstanding the issue with data column 8 as

just reported.

The analog values being reported by the RTTY TLM is another matter, however. As with the M.C. Encoder there is a calibration channel that measures the Precision Reference Voltage. That is channel 40. This channel is currently displaying a value of 782 counts regularly. This value should be 500 as the reference voltage is 0.5000 V. We note that the M.C. Encoder only has a 0 to 1-count error as it reports the reference voltage. We can only conclude that the ADC of the RTTY Encoder is now badly out of calibration. We are observing a bias of +282 counts or it is 56% too high, based only on observing the voltage reference channel.

Pre-2009 RTTY TLM data was in-calibration so, this failure has happened more recently - not in the “Sleeping Beauty” phase, like the Column-8 “all zeros” problem. See Figure 4; frame from March 3, 2009.

f) *Other Spacecraft Electronics* in AO-7 are functioning properly, if they haven't outlived their use. In addition to the BCR, which controls the input voltage to the primary bus, there are three other regulators. There is a 9V regulator located inside the VHF/HF Transponder that works as designed when the satellite is in Mode A, as required. It is not redundant. There is also a pair of 10 V regulator and a pair of 28 V regulators associated with various RF equipment. Both power supplies are auto-redundant and both redundant sets are performing within specification. Since the redundancy is automatic and since we do not have telemetry of which regulator is in use for each pair, we are unable to comment on the status of the redundancy. We can report that the voltage outputs of both the 10.0 V and the 28 V regulators are correct.

There is a set of circuits that have been used to fire the pyro devices, which deployed the 29 MHz dipole antennas. This deployed antenna is a full % wavelength long at the transmit frequency. As such this was a significant deployment event. Each antenna was about 2.5 meters long. The electronics that accomplished this involved an RC delay timer and 4 relay circuits. The timer was designed to deploy the antenna four (4.0) seconds after spacecraft separation. This set of electronic completed its function 4 seconds after separation of AO-7 from Delta.

While everything functioned as designed electronically, we did make one significant mechanical error in our design of this system. The pyrotechnic devices used were indeed, made by Hi-

Shear (this vendor provides many of the smaller ordinance used on the Delta launch vehicle). However, we used a mechanism, which then, redundantly cuts specialized Dacron cords. The severed cords then release the antennas. The devices were not sealed as are typical bolt cutters used in launch vehicle applications. For instance, with the Marmon Clamp Band used for spacecraft release, the two bolt cutters are sealed devices. During test, we noted these “Reefing Line Cutters,” upon detonation, made a significant “BANG.” This, of course, means there was some exhaust from the “action” end of each device. However, we didn’t appreciate the significance of this at the time we did the deployment test. AMSAT, in our design, hadn’t noticed that the two pyros on the +Z antenna were pointed so that this “exhaust” was directed in the +X direction BUT “sadly” the exhaust from the pyro on the -Z antenna was directed in the -X direction. So, inadvertently, we had created a perfect spin up device for our spacecraft. During the real deployment the action of the 4 pyros spun up the spacecraft about the X-axis (in the X-Z plane), AND then the antennas DID deploy. The antennas themselves deployed along the Z-axis and this essentially doubled the moment of inertial of the spacecraft. This nearly instant Mol change (this time, along a good axis) slowed the spacecraft back down again – mostly. However, while we were anticipating a tip off from Delta of a small fraction of an RPM, what the early TLM data showed, when we first acquired the spacecraft at ground stations in the U.S., was a spin rated of several RPM. It was a long time before this author pieced together for certain, what did happen a few seconds after AO-7 left the launcher. This could have been much worse that it was. The two antennas deployed properly, however, these STACER® booms were never designed to execute deployment in an already spinning state. Sometimes we’re lucky. This was one such case. The good news is, the Hysteresis Dampers inside the spacecraft killed this excess angular momentum within a day or two. The spin *period* around the Z-axis slowed down to the 3 min/rev as reported above, and the rest of the ADCS system took over from there.

7.2 Old Satellites and the Old Folks who Built Them (“Dragons live forever, but, not so little boys...” PPM - *Puff the Magic Dragon*).

With the highest respect, it should be noted at this juncture, that a spacecraft system consists not only of the object(s) that are placed into space but, also the people that remain behind on the planet where they came from. It is the people that have a social memory about the object in space. If the reader has worked on spacecraft that have lasted for 5 or

maybe, even 10 years in space, that is one thing - and it is a good thing! But, working with a spacecraft that has lasted for 50 years, actually conjures up different thoughts.

- 1) If I want to compare something happening now on that old bird, where do I get the data from - to compare what I have now to its performance back in 1974? “Now where did I put that? Which box is it in and where is the box?” No One-Drive existed in 1974 dudes. All we had were file cabinets.
- 2) If I explain an action that took place in 1974, do the younger listeners/readers understand what I’m talking about? If I use the term “Operational Amplifier” will they know what I mean when I’m discussing such a device?
- 3) When we started this project the Microprocessor had not yet been invented. Now we’re trying to slow down artificial intelligence. Can anyone relate to a computer made out of discrete gates and shift registers? Where does that past technology stand in relevance, with respect to 2024 technologies - which are expanding exponentially?

8.0 Engineering Outcomes Over 50 Years - A Summary

We believe it is important to summarize the larger scale elements, which we’ve discussed above in some more detail.

8.1 Radiation Dose: The radiation dose received by this spacecraft is perhaps the most interesting aspect of this particular space mission. The total dosage received by the electronics in AO-7 has been accumulated, not rapidly, as a satellite would in a HEO orbit or one that transitions the Van Allen Belts regularly.

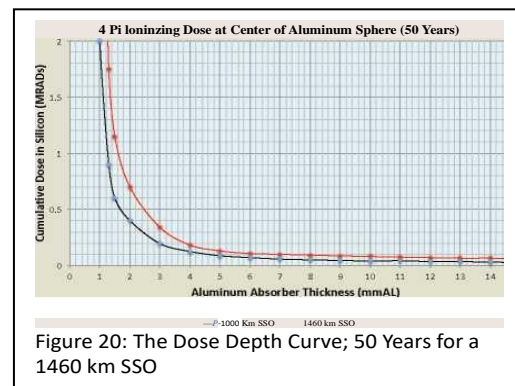

Figure 20: The Dose Depth Curve; 50 Years for a 1460 km SSO

Rather, it has been accumulated in, most would say, a terrible LEO orbit - one that is no longer in use and will not likely be used again for several

reasons. We summarize the total dose by showing you the SPENVIS-like dose depth curve for the AO-7 orbit after 50 years. See Figure 20.

If we summarize what this curve means:

- a) Sensors and wiring just inside the spacecraft structure; say, behind the solar arrays (where there is 12 mm of Al shielding) the cumulative dose has been 0.7 to 2.0 MRADs (Si).
- b) For small modules located above the battery and partially shielded by it (4-6 mm of AL shielding) the cumulative dose has been 100 - 200 kRADs (Si).
- c) For large modules (in two stacks of six modules) and for the average value of radiation accumulated inside the spacecraft (2-3 mm of AL shielding) the cumulative dose received so far is approximately 300-700 KRADs (Si).

Against this radiation input we conclude:

- a) The original CMOS RCA 4000 AD series devices **are** RAD-HARD. They have demonstrated full functionality at 10 V V_{dd} and at slow speeds, at dosage levels in excess of 500 kRADs (Si). We cannot confirm that CMOS parts using analog switches (e.g. CD4016-AD) are able to remain constant in their analog throughput voltage at this dose level. The 4016 used to sample the M.C. Encoder, Channel 6D (Precision 0.5 V Reference) seems to be working correctly as that channel is still in calibration. But, that is one case only.
- b) All Silicon transistors and diodes used, including BC series European transistors survived, with little effect, after a total dosage of 500 kRAD (Si) when accumulated over 50 years.
- c) All known capacitors (e.g. dura-mica, CKR-05, CKR-6 and both Aluminum and Tantalum capacitor show little or no signs of deterioration due to radiation at the 500 kRAD (Si) level.
- d) Carbon composition resistors showed little change in resistance after the accumulation of 500 kRAD (Si) of total dose.
- e) The biggest surprise from AO-7: Metal film resistors seem to be radically changed in resistance during the accumulation of 500 kRADs (Si) total dose. We believe that more research using the data set from AO-7 will allow us to refine the relationship between total dose and resistance value change for RNR-55 and RNR-60 class resistors. We suggest that passive metal film components be

tested more thoroughly in order to demonstrate their stability with increased total dose. **THIS MAY BE THE MOST IMPORTANT FINDING OF THIS PAPER.**

- f) Our precision reference (Silicon) diode had a very limited change in value after receiving in excess of 200 kRADs (Si) cumulative dose.
- g) There is considerably more data available to be analyzed from the AO-7 database, which could yield other information about radiation accumulated over a long mission lifetime.

8.2 The Survival of Individual Piece Parts

AMSAT used many high reliability piece parts in AO- 7. However, we also used many COTS parts. Aerospace experts specifically recommended against some parts, which were used anyway. So, in that regard, we had a “mixed bag” approach to component reliability. What can be said, of relevance, on this topic is:

- a) The most critical systems (e.g. the ECL and the Command Decoders and the Command Receivers) used Hi-Rel devices screened to MIL-STD-883B. One command decoder seems to have failed, however, there are other explanations for the loss of command with this unit.
- b) The most critical systems in the spacecraft were redundant (e.g., command receivers, command decoders, the Battery Charge Regulator; almost all power supplies). One Command RX was lost due to an EMI/EMC failure. See Sect. 4.1. This failure is a design failure coupled with a test failure.
- c) We are aware of two possible places where it is likely that a CMOS device failed in orbit. However, in one of these cases, the failure observed could be explained by the failure of an analog device or even an uplink error.
- d) We particularly want to report on the BCR experiment in which BCR-B utilized output filter capacitors (electrolytic) that were screen Tantalum parts. These were spares from a NASA flight program, while it will be recalled that BCR-A utilized standard, unscreened European ALUMINUM electrolytic capacitors. After 50 years in orbit we can claim that neither set of electrolytic capacitors has failed. It also can be said that we are unaware of any Aluminum electrolytic capacitor failing, which were used on the AO-7 mission. All such capacitors were, we believe, manufactured in Germany.

e) This small satellite performed beyond all expectations regarding the use of piece parts. No one designs for 50 year-long missions - yet. We believe that the most important lesson we can pass-on to other small satellite systems is “test, test and test again.” Bad designs cause failures in space, not bad parts. If you test, test and test again - you’ll find any bad parts along the way - before you get to space.

8.3 Long Term Engineering Experiments - Back to the Photon Propeller

We recall there was one passive experiment associated with the attitude control of this spacecraft and that experiment should still be working. The Photon Propeller, made by simply painting the opposite sides of the canted turnstile antenna black and white, should still be working. But, our interest was to see if the propeller had a reduced spin rate from earlier times. Sadly, the photon propeller calculations, completed by Dr. Karl Meinzer, have not survived. So, we cannot present the originally expected rotation rate. However, the concept is not too difficult to understand. The momentum that can be transferred by a photon to any surface (in this case, to the blade of the antenna) is inversely proportional to the absorptivity (a) of the surface divided by the emissivity (e) of the same surface. On average, the sun “sees” just slightly more than one white blade and one black blade at a time. As the spacecraft rotates the blades change position, however, this average remains about correct while the S/C is in the sun, regardless of the angles involved, during a spin cycle.

Fresh black paint and white paint have a and e values approximately as shown in Table 4:

Table 4: a & e Values of Black and White Paint ⁹

Paint [^]	Black	White
a	0.95	0.25
e	0.85	0.90

So, the a/e of the black surface is about 1.1, while the white surface has an a/e of about 0.3. Both blades have just about the same absorptivity and absorb photons just about equally, however, the white paint reflects most of the photons and energy is thus transferred to the white surface more than to the black surface. This imparts a differential torque between the blades on opposite sides of the structure, which ultimately rotates the spacecraft.

Black paint is quite stable and retains its a and e values over time. However, white paint gets “blacker” as it is degraded by UV radiation. Hence, the a value of the white paint will increase over time. This then, increases the a/e of the white paint side of each propeller blade and the spacecraft should slow down because of this change.

So, did it? How much did the a of the white paint change? We already have enough data on exhibit to provide this answer. We look again at Fig. 11, which shows the spin rate of the spacecraft vs. time (measured here vs. orbit number). If one has a look at the curve imposed across the top of the figure, you will see that this plot gives us the % of time the orbit is in the sun. The plot shows that the spin rate of the satellite, as it begins to settle into its long-term pattern, spins fastest near November of each year and slowest near July when the % sun is highest (and the eclipses are longest). So, very clearly this makes sense. The longer the satellite is in sun, the more time per orbit it is bombarded by photons and the faster it spins. One can also notice that even during one pass the satellite spins up and slows down. The satellite spins fastest near the ascending because it has been in sun for a long time and it spins slowest near the descending node because it has just come out of eclipse, when it starts to spin up again. This all makes good sense. There is a lot of math going on with the actual value of the LTAN or LTDN of the orbit and a primary variable is in what month of the year the measurement is made. Let’s work through this. Next examine Figure 19: The +X & -X Solar Panel Current. This data from the M.C. telemetry data shows the time measured in multiples of how long it takes to sample the same value twice (that is, the length of a telemetry frame). That time is 80.25 seconds. The two solar panels are on exact opposite sides of the satellite; therefore, the time between the red peak and the blue peak is equal to % of the rotation period of the spacecraft. If we do the math, using this data, the period of one rotation is about $2 \times (7.5 \times 80.25 \text{ sec}) = 1204 \text{ sec}$. And that is 20.1 min./rotation. This measurement was made on 19 April 2023. So, to adjust for the difference in spin rate caused just by the Earth orbit eccentricity, we have to look at our plot done back in the 1970s (that’s Figure 11) and look at the bottom X axis of this plot and we see both the orbit number and the year number shown. The best we can do for this exercise is to compare the spin rate in 2023 to the spin rate on the same date in 1975, which is the first year when the spin rate had, more or less, been established for the photon propeller. On 19 April 1975 AO-7 had completed approximately 1560 orbits. So, if we look at the spin period circa orbit 1560 the spin rate, adjusted for Earth orbital

eccentricity effects, will be corrected. Then, once again from Fig. 11, we see that the spin period at that time ranged between 12.0 and 17.25 min./rotation. If we assume the data was taken by observers (in both 1974 and 2023) sometime between the two nodes, then an average spin period would be approximately 14.6 min/rot back in 1974 and in 2023 approximately 20.1 minutes.

We noted above that the momentum exchanged was inversely proportional to the a/s of the surface material. Following through, we make the approximation: s (black paint) = s (white paint) and that neither of these two parameters have changed very much with time. It can then be shown that the spin period (P) is proportional to the a (white paint). We can use the equality:

$$\frac{P_{1974}}{P_{2023}} = \frac{\alpha_{1974}}{\alpha_{2023}}$$

And substituting values:

$$\frac{14.7}{20.1} = \frac{0.250}{\alpha_{2023}}$$

And this yields:

$$\alpha_{2023} = 0.342$$

While the math here is a little bit rough and we haven't accounted fully for some changes to the orbit; especially sun angle information we've learned about very recently, we believe this is a good approximation for the deterioration of the white paint on the antenna blades - over a 50 year time exposure to UV from the sun.

When this author approached the chemists from the Materials Engineering Branch at NANSAs/GSFC back in 1973, I inquired about the stability of white paint and what was the best type to use. I explained the application. I was sent to the lead laboratory technician, whom I'd already befriended previously. Carol Clatterback and I were to become fairly close friends over the next ten years or so. After giving Carol the same story, he went off to a cabinet behind his desk and returned with a small can; he referred to a lab notebook; then handed it to me. "You'll want to use this," he said. "It won't change much due to UV. I've been messing with this stuff for years. I think it is pretty good now. And, hey, I'd like to hear how your experiment turns out. A photon propeller, huh?"

Well, Carol, your white paint degraded about 9% in absorptivity over 50 years in space. Most white paints would be black after 50 years in orbit. Yes, the photon propeller still works and so did Carol's white paint! Thank you Carol and thank you NASA!

8.4 Orbit Perturbations of Higher SSOs

It was essential, given the SECOND LIFE of AO-7 that we understand how the orbit would change as the satellite lived on. The author neglected this task for all t -o-o long. As we approached the current epoch, the authors realized the expected drift in the orbit *mean sun time* did not coincide with what we had anticipated, using only the Earth's J_2 perturbation term. The times of 100%-sun did not seem to coincide with those expected, although we could still see more eclipse time in July and less in November. The author began to investigate the orbit drift using just CSpOC TLEs as the source. What we found was astounding. It so surprised the author that I contacted, Dr. Karl Meinzer and shared what I was seeing with him. To make a very long story shorter, we discovered - what we thought was an entirely new perturbation of sun-synchronous orbits. And to a reasonable extent this is the case. This so surprised (and to be fair, excited) us that together we wrote a full paper on this different perturbation we had found. It was submitted and accepted for publication by the USU/AIAA Small Satellite conference this year. The paper is **SSC24-S1-04**. We encourage anyone who has an interest in orbital mechanics and especially in SSOs to please read the paper. We believe you will be almost as surprised as we were - almost.

The primary output from the referenced paper is the relationship between the RAAN (O) and the orbit sun angle vs. time from injection. It so happens, we need a variant of that plot now, in order to show the reader, what is in store next for AO-7; as it moves forward. Figure 21 is, based entirely on the orbital TLE data of AO-7. It demonstrates that the orbital drift, is NOT linearly increasing or decreasing in O (as the Earth's J_2 predicts). Rather, (and surprise!) it varies sinusoidally, due to a combination of two perturbations acting simultaneously on the spacecraft, one caused by the Earth and one caused by the *Sun*. Please read our other paper for details. Figure 21 shows that this sinusoid has a period of 29 years and has an amplitude of approximately $\pm 40^\circ$. It is important to add some additional information to this graphic.

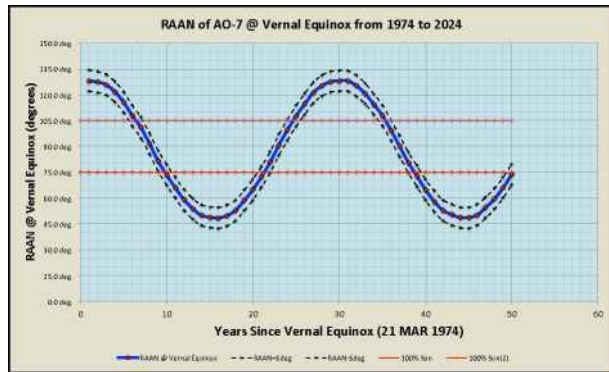

Figure 21: RAAN Value of AO-7 Orbit Over Lifetime

The black dashed “envelope”, shown on either side of the blue plot, is the maximum extent of the “wobble” of the orbit caused by the Earth’s orbital eccentricity. Most of the readers will be aware of this variation in mean sun time over the year, if you have worked with SSOs before. The two horizontal lines, shown at constant Q at 105° and 75° are the RAAN values on March 21 each year (or equivalently, the sun angles) where the orbit goes into/out of full sun. These two angles are valid for a SSO at 1460 km circular altitude. The important concept being conveyed here is IF the blue RAAN curve AND its full envelope (inside the two black lines), falls entirely within the shaded area between 75° and 105° then the orbit will be in 100% sun.

With this detail in mind, we note that AO-7, later in 2024 will once again be approaching the $Q = 90^\circ$ condition. Near the end of this year it will enter a 100% sun condition. And, this condition will last for about 3.4 years. With no eclipse, the ECL and it’s 24- hour timer will consistently keep our old spacecraft switching between Mode A and Mode B alternately for several years without the need to even send commands to the spacecraft. Further, with no eclipse, power will remain constant for the ECL and it will retain all of the modes as they are set by command, without having to reset these states of the spacecraft every single orbit. And mostly, the spacecraft will be able to, once again, provide global communications without interruption. Not having a battery becomes much less of a burden, when managing the spacecraft. The orbit perturbation just described has always existed. However, we didn’t know about it until late 2023. It has done the old spacecraft (which is responsible for re-discovering the perturbation) a great favor. The fact that the orbit sun angle oscillates about the 90° sun angle as its average value, means that the spacecraft, over long time will spend a much larger percentage of its time in

full sunlight. Nothing could make a battery-less spacecraft more delighted!

9.0 The Technological Relevance of a 50-Year-Old Space System

As we draft this paper, one cannot help but think about the changes in ALL technology over the years since 1974; yet, writing this engineering evaluation and even comparing what happened on Orbit 69 and then on Orbit 202,206 - with a mere 431,600 hours between the two - still doesn’t convey this time separation in “technology time”. We know that technology is changing with time exponentially. It is profoundly true that people just don’t think exponentially. So on average, most humans don’t even realize what previous technology was like and how rapidly it is changing with time, even as they interact with it in their daily lives. A 50-year jump in technology is hard to deal with, mentally, for all of us. Let’s consider a few aspects of this issue. All of the physics used to make AO-7 a reality - is still in play. The vast majority of the electronic devices used to make AO-7 do not still exist. Many of the metal materials used are still available. However, most of the organic materials have changed. Adhesives are different. Some organic materials have survived: e.g., Kapton ® then is the same as Kapton now - and it is used abundantly. Thermal blankets are really just about the same. However, computational capabilities for spacecraft are so vastly different they really need not be compared. AO-7 was assembled less than 2 years before the emergence of the Intel 8008 microprocessor. So, it was designed at the very end of an era. There is shock value in telling younger engineers how many logic gates were assembled with small-scale integrated circuits in order to fulfill our designs. And, there were many such grand-scale projects back then. In order to emulate a general- purpose computer, many digital engineers worked hard on vast arrays of logic gates. However, it is generally believed by this author that such stories are for history books. There is no significant value in analyzing old digital circuit designs in order to glean insight into new designs. There may be more value in assessing old RF designs or even analog designs, however, these are likely debatable topics. Due to the exponential nature of technologies and the homo sapiens who developed them - if we built a spacecraft today and it lasted for 50 years (assuming the orbit did), it would be more out-of-date in 2074 than AO-7 is now. Hence, we acknowledge that there is not that much value in having a 50-year-old spacecraft technology

demonstrator. So, old AO-7 may never be repeated intentionally. In fact, AMSAT never intended to design a spacecraft that would last longer than our own collective lifetimes. After all, the author was 27 years old in 1974. I never could have imagined I'd be writing this paper. So, please take this "happening" for what it is. It is unlikely, probabilistically, that such a spacecraft could exist this long. And, it is certainly an opportunity for all of us to witness the past - and to almost touch it. However, beyond the physics lessons it can teach us, it is just nice to shake hands with the past!

10.0 The Future For The Oldest Satellite Still Functioning

There is nothing in AO-7's observed condition, which suggests it will quit tomorrow. The solar arrays seem to have degraded between 20% and 30%, however, radiation data for Silicon Solar Cells suggests the worst damage is behind us. The spacecraft system as designed can cope well with slowly declining power and even more importantly the users have learned to adjust their operating behavior, in order to adapt to the prevailing power conditions. The CMOS seems as though it can continue to function, and, once again, most of the radiation damage has been done. Simplistically, most protons arriving at AO-7 now are going through holes left by prior protons. That is one way to explain this. It is true that threshold biasing of each CMOS pair must be continuing. We simply don't know where that deterioration has gotten to. Perhaps the most likely end-of-life scenario will be a critical piece part failure in the BCR. Or the OPEN battery cell could go back to SHORT again - third time unlucky. So, there is a real, finite, opportunity that this spacecraft could outlive 100% of those individuals who designed it. That would be another kind of first, perhaps. I'm avoiding theological discussions for now.

There are many bits and pieces of engineering and physics from which we can continue to learn. We would like to offer the SmallSat Community the opportunity to participate. We believe we can learn much more about the analog offsets we are witnessing and *if* we can recalibrate some of the TLM channels we may be able to learn more about other Experiments in the spacecraft. There is much more to be done to model the radiation environment. Detailed modeling of the inside of the spacecraft is possible and more careful modeling of the orbit can be done to improve total dose assessments. The details of the damage to various CD4000-AD series devices could likely be carried

out. It would be interesting to answer the question: Why did NASA/GSFC believe RCA CMOS of the day would last only for 3 years in a 1460 km orbit, when in fact AO-7 has lasted 50 years in that environment-so far? Albeit, the spacecraft took a 21 yearlong nap - and reviewing that sleep period may make an interesting contribution to physics. Did our CMOS anneal to any significant degree while there was zero voltage on the CMOS devices? Remember, while we had no V_{dd} on the CMOS, they were still being radiated in the same orbit. The logic functionality of the vast majority of these devices can be shown to be "acceptable given the voltage and speed conditions under which we are using them." We, the authors, would like to understand from those more skilled than we are in radiation physics, how is this possible? It would be helpful if there were something fundamental here, which can be learned for future spacecraft (large or small). If you might have an interest in participating in future investigations using our databases or ones you might want to develop yourself, we would welcome you joining us. If there are experiments that come to mind (from communications demos to physics tests we could perform) we would greatly appreciate your ideas. We can make the spacecraft as available to you as the old bird can be. So, you are invited to join in this Small Satellite adventure.

In closing, I wanted to try to put you into the head of this author. I have been thinking many thoughts that haven't been in my mind for 50 - and sometimes more - years. So many times, I've wanted to reach for a file on my laptop or a file in a manila folder, only to realize, that information has been gone for *truly* a long time. It is hard to remember (even for this author) what it really was like before the Internet. And, I can tell you, writing this paper, certainly has made me realize how all "this" has changed ME.

Then there is the situation where I wonder if I can ask Tom about that...OOPS, I forgot, he died a few years ago. More than 50% of the individuals this author has named in this paper are now gone. NOTE: I haven't counted but I'm certain this is true. If you were wondering what this author went through in writing this paper, try thinking about the details of what you were doing, on any endeavor, 50 years ago. See how it goes! Some readers of this are not even 50 years old yet, so you don't count! The AO-7 spacecraft has quite a high probability of outliving all who started this program. Think about all of this, when you think about what can and cannot be done with your next small spacecraft.

11.0 Acknowledgements

The authors would particularly like to recognize the many special people at NASA's Goddard Space Flight Center who simply made AO-7 and, indeed, the Amateur Satellite Program possible. While most of the individuals are no longer living, we'd like to acknowledge their importance to the evolution of small satellites, in this instance, by means of accepting and enabling our program.

We'd like to acknowledge the Center Director, John F. Clark (W3GYU) for allowing this program to nurture and grow at NASA/GSFC. He knew who we were, and I believe he kept a watchful eye. But, he never stopped us and every time we needed support, it was there.

We'd like to acknowledge Gerry Burdette, the Deputy Program Manager of ITOS in 1974, who made sure we tested everything properly and that we didn't harm his spacecraft. Before launch, he approached the author, when we were both on Level 5 of the SLC-2W gantry. I was looking at the array of all three spacecraft, just before the fairing went on. He pointed to AO-7 and said, "King, that's a great little spacecraft you've got there, I hope it works well." I'm pretty sure my mouth dropped open. Gerry, shortly after this conversation, became a Radio Amateur himself and became a member of AMSAT. It's a true story. He made us work for what we got but he was perfectly fair about it. I learned a lot about project management from him.

We'd like to thank the entire Delta L/V Team who managed and modified a "Vehicle Built for Three" just for us. Our special thanks are made to Robert Goss, John Tomasello, Tom LaVelle and J.D. Kraft. Each of these NASA employees made sure it all happened in our favor. These particular individuals went way out of their way to pave the way for small satellites into the future. Delta, of course, was also McDonnell-Douglas who made the Delta L/V. They also made our experience one that was first class. They too deserve credit for helping to create the new world of small satellites.

And, we'd like to thank the many, many, spacecraft technologists at NASA/GSFC who helped us, not only by giving us spacecraft bits and pieces but, far more importantly, they taught us what we didn't know - which was a lot. There are too many individuals to name and there are even too many favors to recall. We were just kids then, and GSFC was our "candy store." It is impossible to express our gratefulness for what each of them taught us over those years! NASA/GSFC was a great place to

work and learn.

My quiet and special thanks to Marie Marr our wonderful AMSAT technician. Marie was THE paid AMSAT employee. Marie had the most awful job of all. She fabricated the wiring harness for AO-7. For me, I couldn't watch her "do her thing." She ultimately made a mass of colored Teflon wire look like a piece of art. I'll never appreciate how she did it. Marie had another skill. She knew where every single piece part was that existed at NASA/GSFC and she knew where and how to get them. When all else failed our cry was, "Marie can you find this?" She always did. She too is now gone! I miss her most!

12.0 Afterthought

So, now that you've read this story, if you've managed to work through it, perhaps we can revisit the Voyager 1 & 2 comparison. Well, it certainly must be acknowledged, AO-7 never discovered any new moons around Saturn. Nor did it witness Io's volcanoes in action. And, this spacecraft did not expand everyone's minds the way only the two Voyager spacecraft have done. Voyager 2 was, and still is, one of the most fantastic achievements of mankind. But, now that you know what went into the little bird described here, and then what it has accomplished, I think you'd have to agree, it qualifies to be characterized as a *valid* spacecraft. And it did enlighten several thousands of students who learned about orbital mechanics and telemetry for the first time. We can even say it helped to demonstrate that Search & Rescue satellites could save lots of lives. We also think it was a pretty good technical effort, and is, perhaps (you might admit) one of the better Smallsats ever. Certainly, it was worth the \$38,000 USD that AMSAT put into it. And, that is still true if you throw in the NiCd battery, the 16 OGO solar panels and some white paint contributed by NASA/GSFC - for free.

So, if you will, please give OSCAR a place in history. This little "spacecraft that could" deserves it. [I think I can; I think I can...]

13. References

- 1a. Meinzer, K., "*Lineare Nachrichtensatellitentransponder durch nichtlineare Signalzerlegung*", Inaugural Dissertation zur Erlangung der Doktorwürde des Fachbereichs Physik der Philipps-Universität Marburg/Lahn, 1973
- 1b. Kahn, L.R., "*Comparison of Linear Single-Sideband Transmitters with Envelope Elimination and Restoration Single-Sideband Transmitters*", Proc. I.R.E., Vol. 44, (Dec 1956) p.p. 1706.
2. Davidoff, M.R., "*The Satellite Experimenter's Handbook*", ARRL, Pub. No. 50, (1984), ISBN 0-87259-004-6.
3. White, H.D., Lokerson, D.C., "*The Evolution of IMP Spacecraft MOSFET Data Systems*", IEEE Transactions on Nuclear Science, **18(1)**: p.p. 233-236, ISSN 0018-9499.
4. Klein, P.I., Soifer, R., "Intersatellite Communications Using the AMSAT-OSCAR-6 and AMSAT-OSCAR-7 Radio Amateur Satellites", Proc. of the IEEE, (Oct 1975), p.p. 1527-1528.
5. Davidoff, Op. Cit.
6. Davidoff, M.R., "*The Radio Amateur's Satellite Handbook*", ARRL, Pub. No. 232, (1998), ISBN 0-87259-658-3.
- 7 a. <https://www.sarsat.noaa.gov/hi-story-of-the-sarsat-program>
- 7b. <https://www.cospas-sarsat.int/9images/content/articles/Quick-stat-SAR.pdf>
8. <https://www.courses.ansys.com/index.php/courses/intro-to-orbit-types/lessons/molniya-lesson-7/>
9. Wertz, J.R., et al., "*Space Mission Engineering: The New SMAD*", Microcosm Press, Space Technology Library, (2011), p.p. 695, Table 22-14, ISBN 978-1-881-883-15-9 (pb)(acid-free paper).